

=BM/4.9 / L1 → L1 / =ZM/1.0
 =BM/4.9 / L2 → L2 / =ZM/1.0
 =BM/4.9 / L3 → L3 / =ZM/1.0

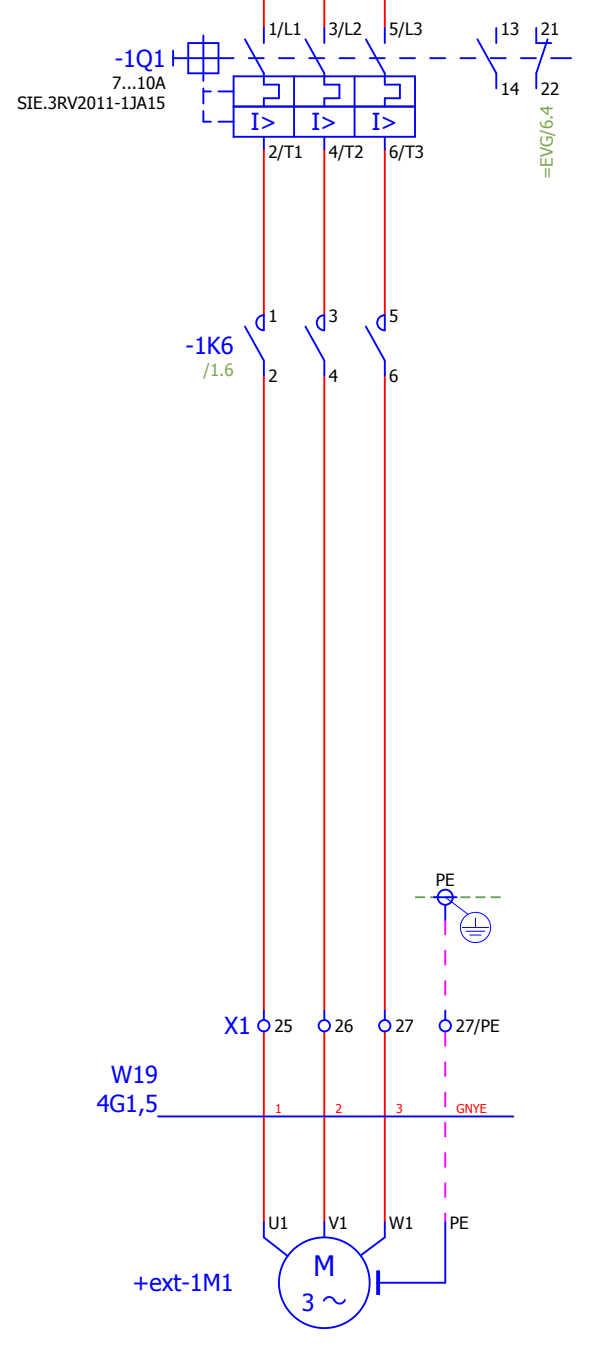

Wasser dosieren

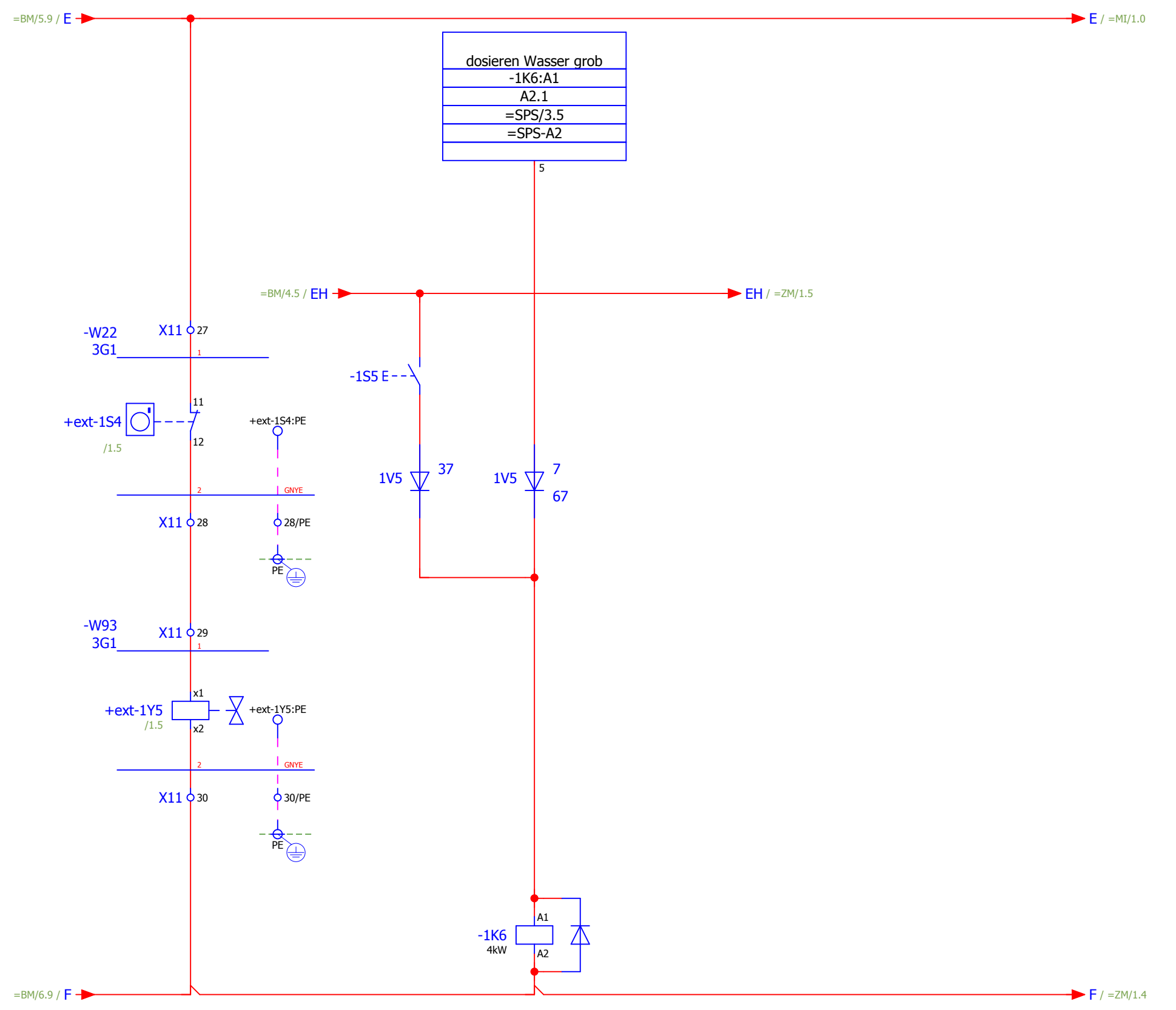

Wasser dosieren

=BM/6

=ZM/1

Änderungsdatum	13.11.2015	Projektverantwortlicher	R. Heer
Datum	09.11.2015		
Bearbeiter	Dennis_Dercho		
Index			



Riedstraße 10
 79787 Lauchringen
 Tel: +49(7741)9199-0
 Fax: +49(7741)-9199-11

Micromix GmbH
 Micromix 124_15 SB-PC-Scan

Wasser Dosieren

Anlage/Ort	= WA + SC	Blatt	1
		Seite	1
1333-60454			