

2006 International ANSYS Conference

May 2-4, 2006

Predicting Fatigue Life with ANSYS Workbench

**How To Design Products That Meet Their Intended Design
Life Requirements**

Raymond L. Browell, P. E.

Product Manager New Technologies
ANSYS, Inc.

Al Hancq

Development Engineer
ANSYS, Inc.

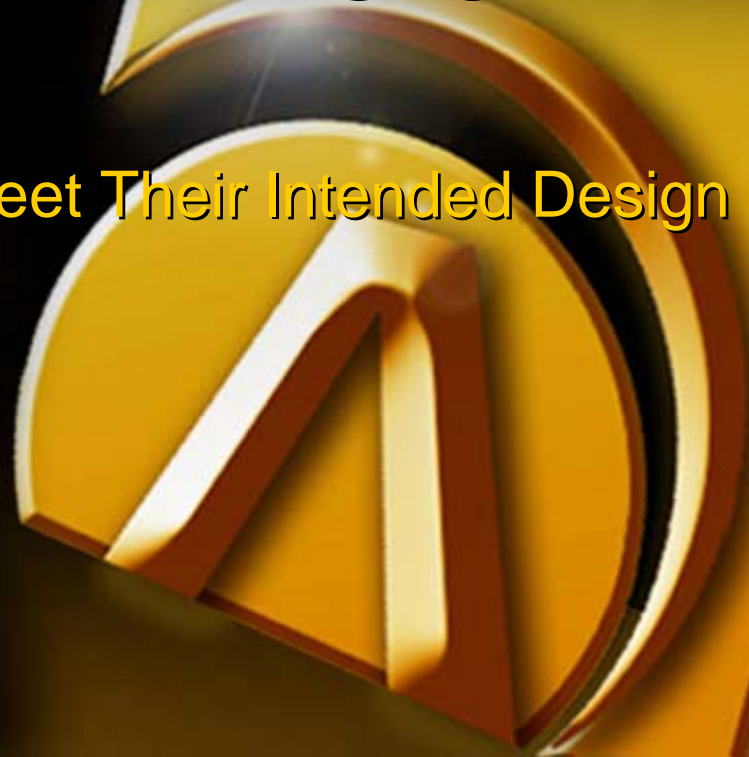

Fatigue Agenda

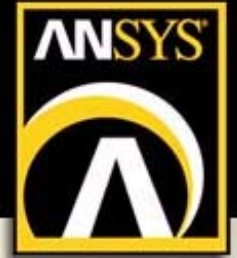

- General Fatigue Review
- Fatigue Analysis in Workbench
- Working with Legacy Models
- Optimization with Fatigue
- Fatigue Within Workbench Fits Into Everyone's Process!
- Questions and Answers

General Fatigue Review

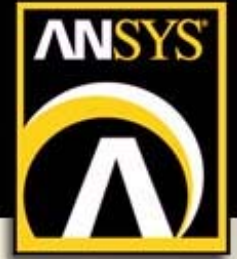

- Why Fatigue Analysis?
 - While many parts may work well initially, they often fail in service due to fatigue failure caused by repeated cyclic loading
 - In practice, loads significantly below static limits can cause failure if the load is repeated sufficient times
 - Characterizing the capability of a material to survive the many cycles a component may experience during its lifetime is the aim of fatigue analysis

General Fatigue Review

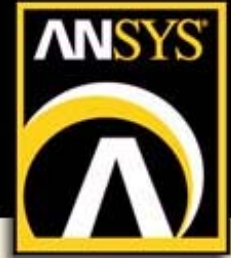

- Common Decisions for Fatigue Analysis
 - Fatigue Analysis Type
 - Loading Type
 - Mean Stress Effects
 - Multiaxial Stress Correction
 - Fatigue Modification Factor

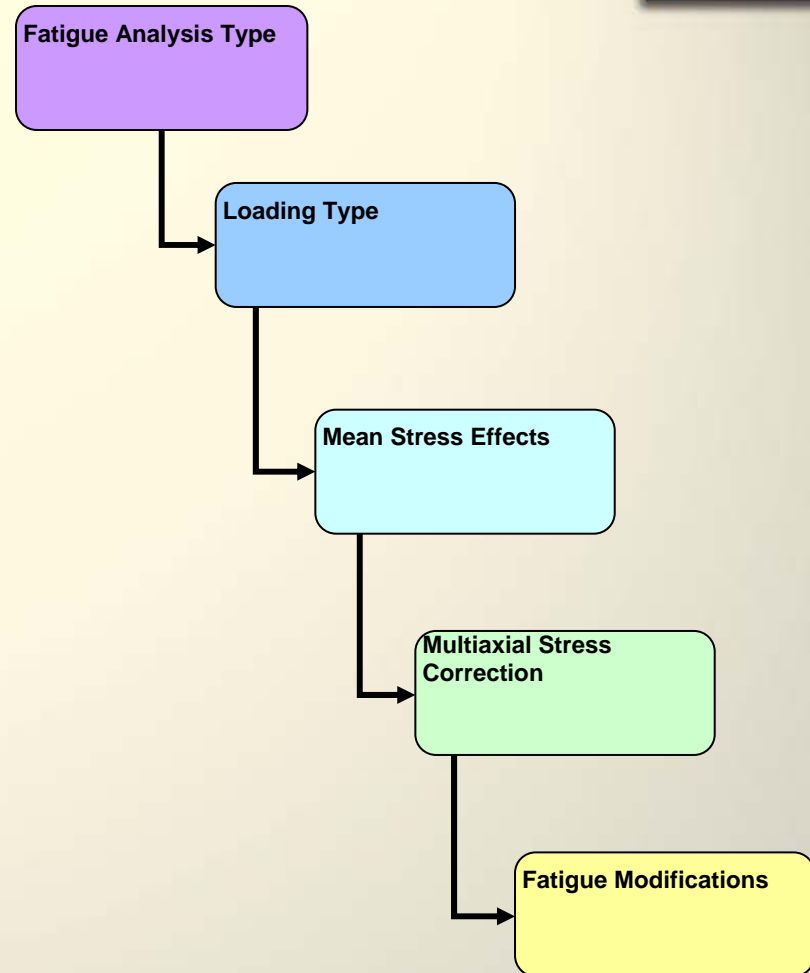

General Fatigue Review

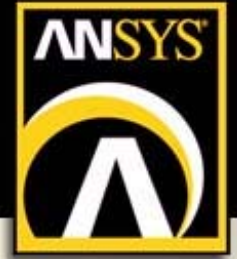

- Fatigue Analysis Types
 - Strain Life
(Available in ANSYS Fatigue Module)
 - Stress Life
(Available in ANSYS Fatigue Module)
 - Fracture Mechanics

General Fatigue Review

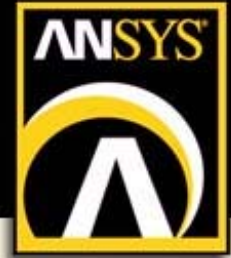

- Strain Life
 - Strain can be directly measured and has been shown to be an excellent quantity for characterizing low-cycle fatigue
 - Strain Life is typically concerned with crack initiation
 - In terms of cycles, Strain Life typically deals with a relatively low number of cycles and therefore addresses Low Cycle Fatigue (LCF), but works with high numbers of cycles as well

| Details of "Fatigue Tool 3" | |
|---------------------------------------|------------------------|
| Materials | |
| Fatigue Strength Factor (Kf) | 1. |
| Loading | |
| Type | Fully Reversed |
| <input type="checkbox"/> Scale Factor | 3. |
| Options | |
| Analysis Type | Strain Life |
| Mean Stress Theory | Morrow |
| Stress Component | Equivalent (Von Mises) |
| Infinite Life | 1.e+009 |

- Low Cycle Fatigue usually refers to fewer than 10^5 (100,000) cycles
- The Strain Life approach is widely used at present

General Fatigue Review

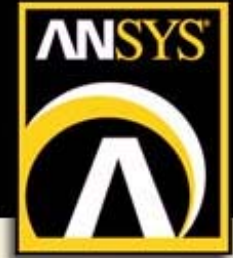

- **Strain Life**

The Strain Life Relation equation is shown below:

$$\frac{\Delta \varepsilon}{2} = \frac{\sigma_f}{E} (2N_f)^B + \varepsilon_f (2N_f)^C$$

$\frac{\Delta \varepsilon}{2}$ = Total Strain Amplitude

$\Delta \sigma$ = 2 x the Stress Amplitude

E = Modulus of Elasticity

N_f = Number of Cycles to Failure

$2N_f$ = Number of Reversals to Failure

The two cyclic stress-strain parameters are part of the equation below:

$$\Delta \varepsilon = \frac{\Delta \sigma}{E} + 2 \left(\frac{\Delta \sigma}{K'} \right)^{1/n'}$$

σ_f = Fatigue Strength Coefficient

B = Fatigue Strength Exponent (Basquin's Exponent)

ε_f = Fatigue Ductility Coefficient

C = Fatigue Ductility Exponent

K' = Cyclic Strength Coefficient

n' = Cyclic Strain Hardening Exponent



General Fatigue Review

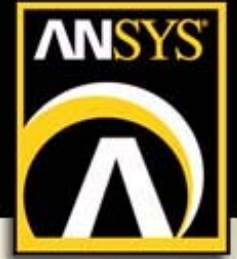

- Strain Life
 - For Strain Life, the total strain (elastic + plastic) is the required input
 - But, running an FE analysis to determine the total response can be very expensive and wasteful, especially if the nominal response of the structure is elastic
 - So, an accepted approach is to assume a nominally elastic response and then make use of Neuber's equation to relate local stress/strain to nominal stress/strain at a stress concentration location



General Fatigue Review

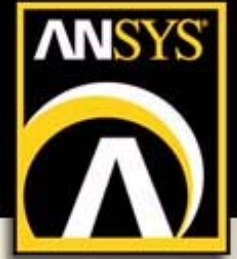

- Strain Life

To relate strain to stress we use Neuber's Rule, which is shown below:

$$\varepsilon \sigma = K_t^2 e S$$

ε = Local (Total) Strain

σ = Local Stress

K_t = Elastic Stress Concentration Factor

e = Nominal Elastic Strain

S = Nominal Elastic Stress



General Fatigue Review

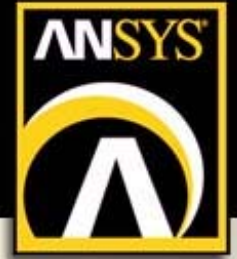

- Strain Life
 - Simultaneously solving Neuber's equation along with cyclic strain equation, we can calculate the local stress/strains (including plastic response) given only elastic input
 - Note that this calculation is nonlinear and is solved via iterative methods
 - ANSYS fatigue uses a value of 1 for K_t , assuming that the mesh is refined enough to capture any stress concentration effects
 - Note: This K_t is not be confused with the Stress Reduction Factor option which is typically used in Stress life analysis to account for things such as reliability and size effects

General Fatigue Review

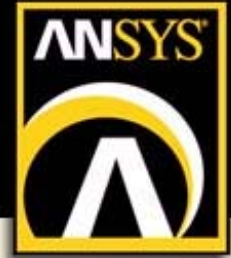

- Stress Life
 - Stress Life is based on S-N curves (Stress – Cycle curves)
 - Stress Life is concerned with total life and does not distinguish between initiation and propagation
 - In terms of cycles, Stress Life typically deals with a relatively High number of cycles
 - High number of cycles is usually refers to more than 10^5 (100,000) cycles

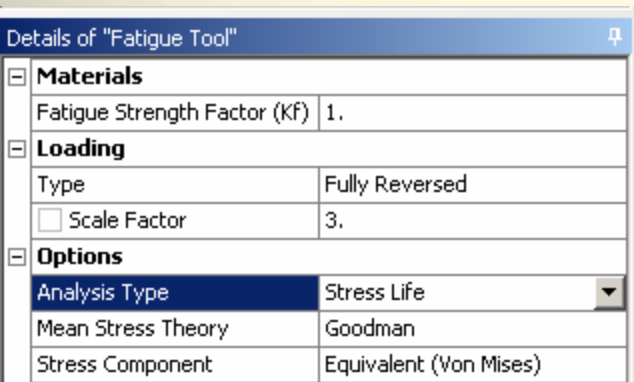

- Stress Life traditionally deals with relatively high numbers of cycles and therefore addresses High Cycle Fatigue (HCF), greater than 10^5 cycles inclusive of infinite life

General Fatigue Review

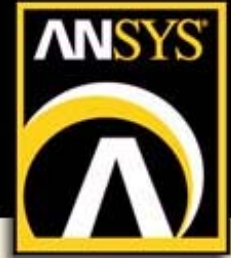

- Fracture Mechanics
 - Fracture Mechanics starts with an assumed flaw of known size and determines the crack's growth
 - Fracture Mechanics is therefore sometimes referred to as "Crack Life"
 - Fracture Mechanics is widely used to determine inspection intervals. For a given inspection technique, the smallest detectable flaw size is known. From this detectable flaw size we can calculate the time required for the crack to grow to a critical size. We can then determine our inspection interval to be less than the crack growth time.
 - Sometimes, Strain Life methods are used to determine crack initiation with Fracture Mechanics used to determine the crack life therefore:

$$\text{Crack Initiation} + \text{Crack Life} = \text{Total Life}$$

Fatigue Analysis in Workbench

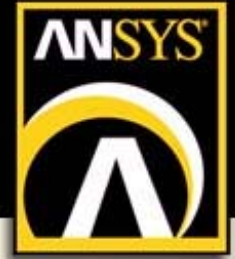

- ANSYS Fatigue Module
 - Integrated into the ANSYS Workbench Environment
 - ANSYS Fatigue Module is able to further leverage advances that the ANSYS Workbench offers such as:
 - CAD support including Bi-Directional Parameters
 - Solid Modeling
 - Virtual Topology
 - Robust Meshing
 - Hex-Dominant Meshing
 - Automatic Contact Detection
 - Optimization
 - Design for Six Sigma
 - Robust Design that the ANSYS Workbench offers

Fatigue Analysis in Workbench

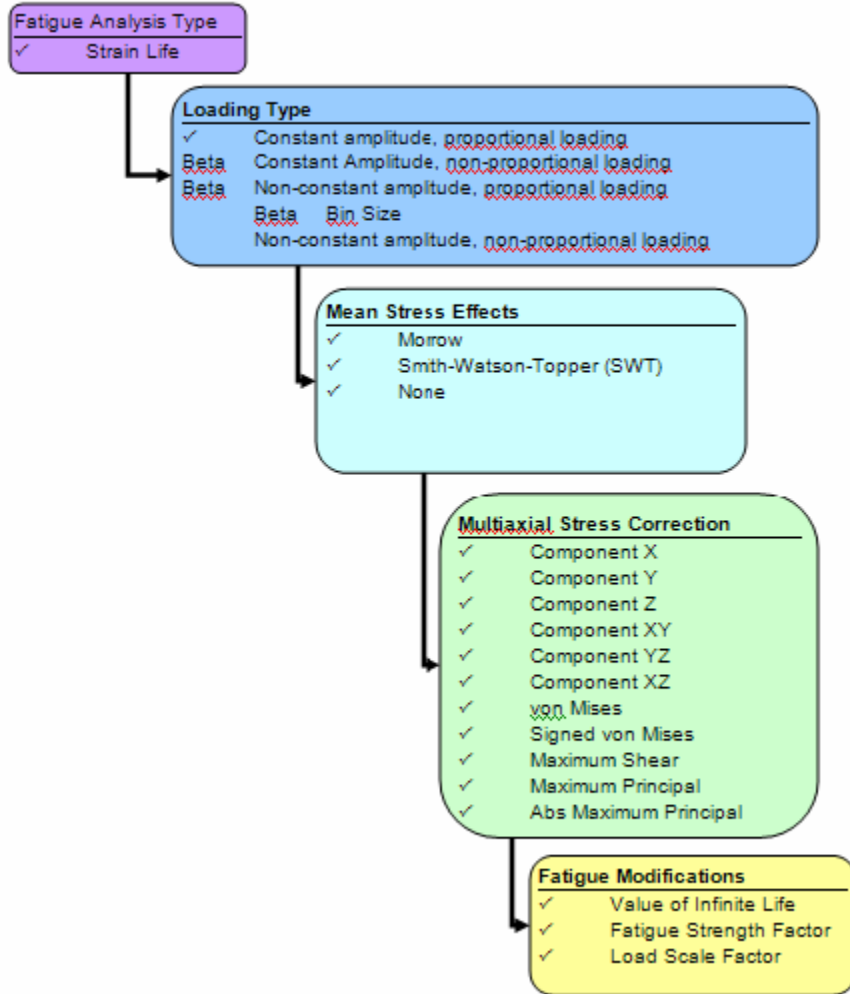
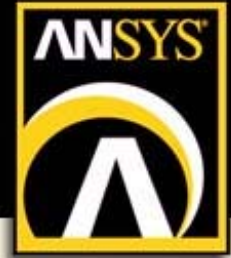

- Strain Life Decisions for Fatigue Analysis
 - Loading Type
 - Mean Stress Effects
 - Multiaxial Stress Correction
 - Fatigue Modification Factor

Fatigue Analysis in Workbench

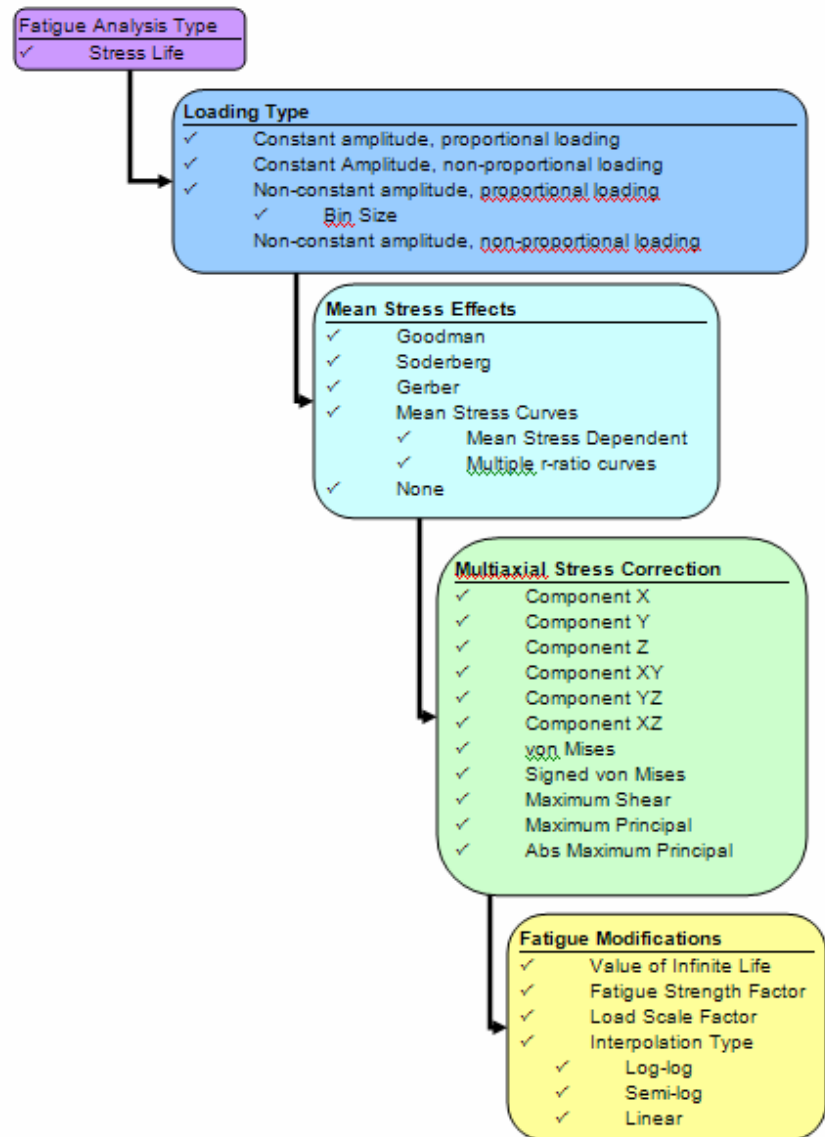
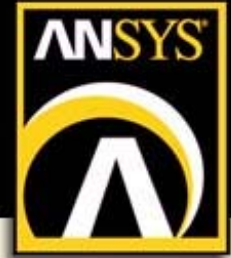

- Stress Life
 - Decisions for Fatigue Analysis
 - Loading Type
 - Mean Stress Effects
 - Multiaxial Stress Correction
 - Fatigue Modification Factor

Fatigue Analysis in Workbench

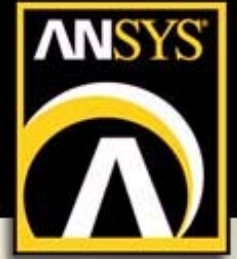

- Loading Types
 - Constant amplitude, proportional loading
 - Constant amplitude, non-proportional loading
 - Non-constant amplitude, proportional loading
 - Non-constant amplitude, non-proportional loading

Fatigue Analysis in Workbench

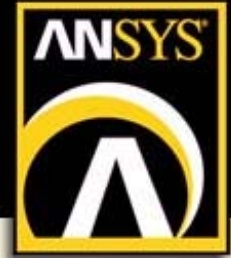

- Constant amplitude, proportional loading
 - Loading is of constant amplitude because only one set of FE stress results along with a loading ratio is required to calculate the alternating and mean values

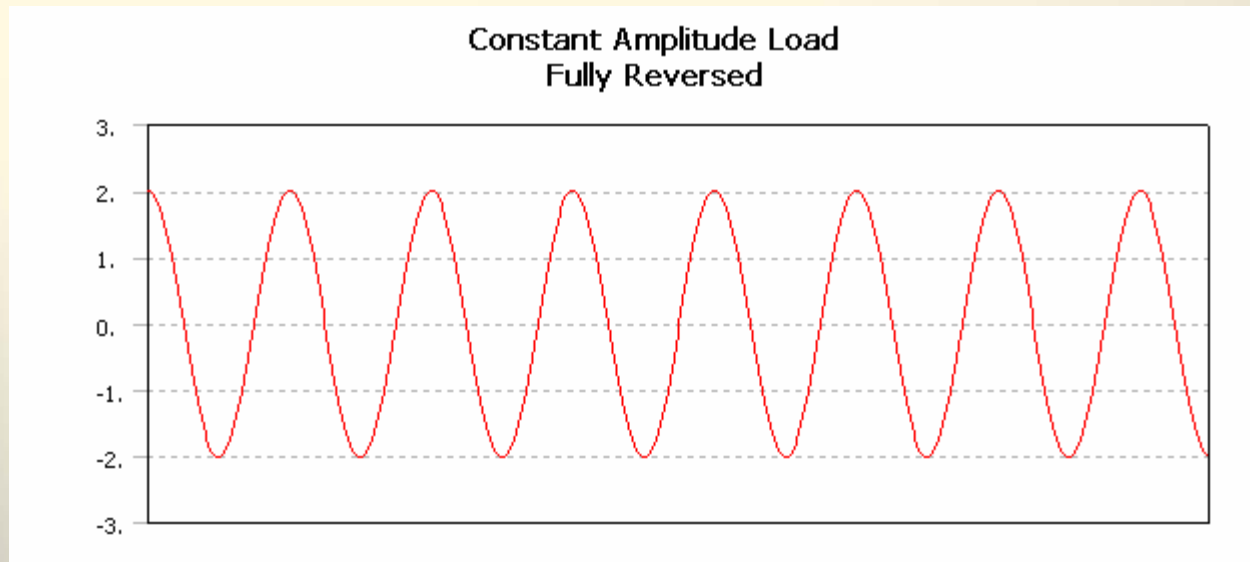

Fatigue Analysis in Workbench

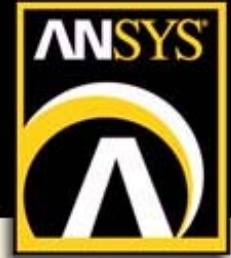

- Constant amplitude, proportional loading
 - Is the classic, “back of the envelope” calculation describing whether the load has a constant maximum value or continually varies with time
 - The loading ratio is defined as the ratio of the second load to the first load ($LR = L2/L1$)
 - Common types of constant amplitude loading are:
 - Fully reversed (apply a load, then apply an equal and opposite load; a load ratio of -1)
 - Zero-based (apply a load then remove it; a load ratio of 0)

Fatigue Analysis in Workbench

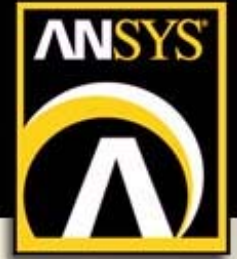

- Constant amplitude, proportional loading
 - Loading is proportional since only one set of FE results are needed (principal stress axes do not change over time)
 - Since loading is proportional, looking at a single set of FE results can identify critical fatigue locations.
 - Since there are only two loadings, no cycle counting or cumulative damage calculations need to be done

Fatigue Analysis in Workbench

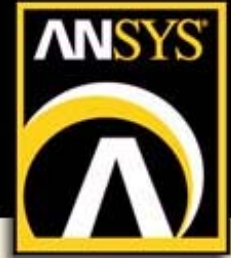

- Constant amplitude, non-proportional loading
 - Looks at exactly two load cases that need not be related by a scale factor
 - Analyses where loading is proportional but results are not
 - The loading is of constant amplitude but non-proportional since principal stress or strain axes are free to change between the two load sets
 - This happens under conditions where changing the direction or magnitude of loads causes a change in the relative stress distribution in the model. This may be important in situations with nonlinear contact, compression-only surfaces, or bolt loads

Fatigue Analysis in Workbench

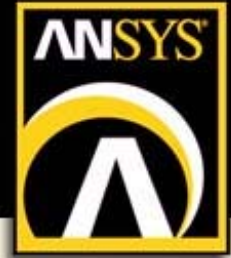

- Constant amplitude, non-proportional loading
 - This type of fatigue loading can describe common fatigue loadings such as:
 - Alternating between two distinct load cases (like a bending load and torsional load)
 - Applying an alternating load superimposed on a static load
 - No cycle counting needs to be done
 - But since the loading is non-proportional, the critical fatigue location may occur at a spatial location that is not easily identifiable by looking at either of the base loading stress states

Fatigue Analysis in Workbench

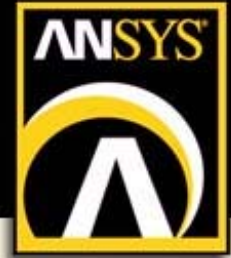

- Constant amplitude, non-proportional loading

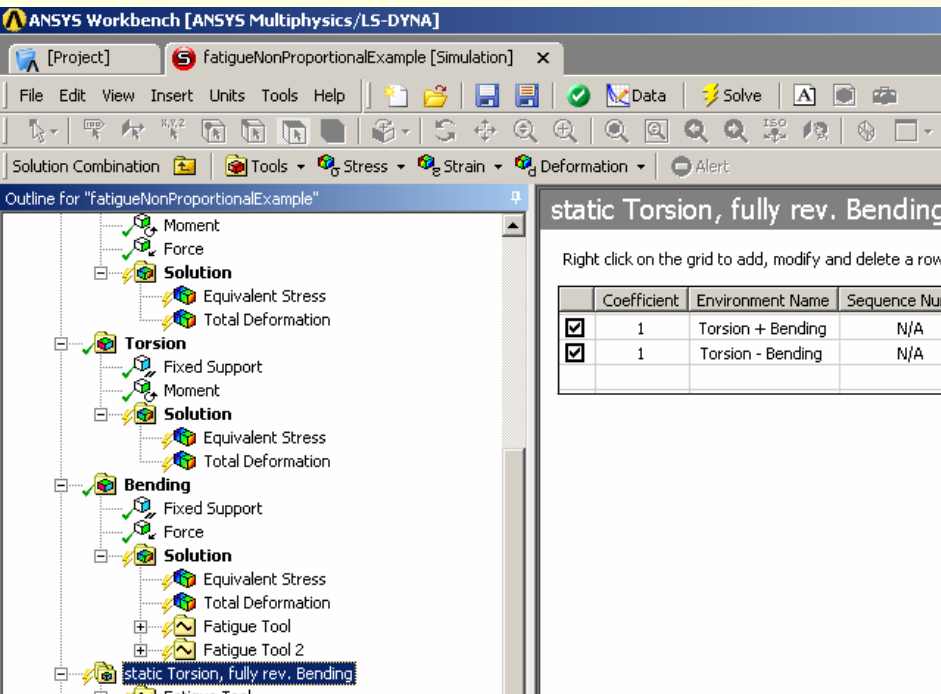

- Fatigue tools located under a solution branch are inherently applied to that single branch and thus can only handle proportional loading

- In order to handle non-proportional loading, the fatigue tool must be able to span multiple solutions
- This is accomplished by adding a fatigue tool under the solution combination folder that can indeed span multiple solution branches

Fatigue Analysis in Workbench

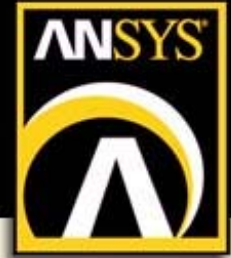

- **Non-constant amplitude, proportional loading**
 - Instead of using a single load ratio to calculate alternating and mean values, the load ratio varies over time
 - Think of this as coupling an FE analysis with strain-gauge results collected over a given time interval
 - Since loading is proportional, the critical fatigue location can be found by looking at a single set of FE results

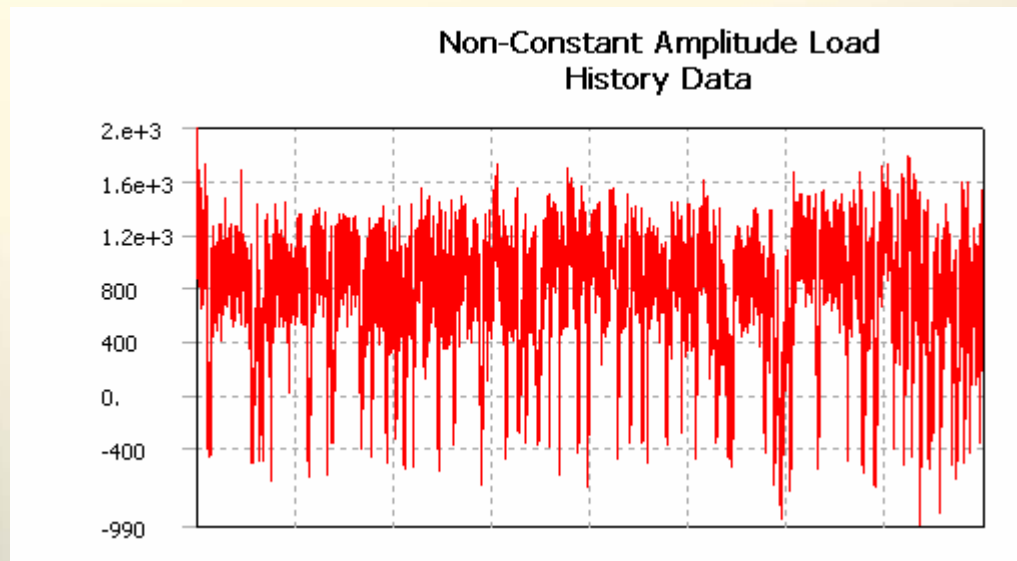

Fatigue Analysis in Workbench

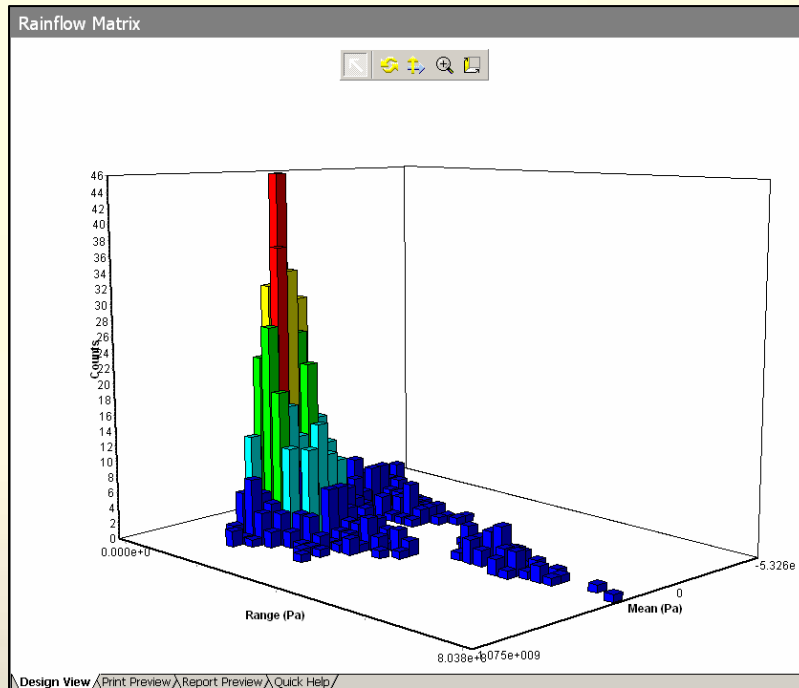
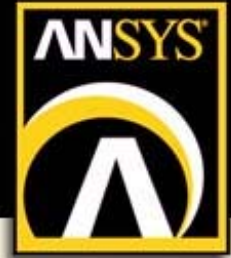

- **Non-constant amplitude, proportional loading**
 - However, the fatigue loading which causes the maximum damage cannot easily be seen
 - Thus, cumulative damage calculations (including cycle counting such as Rainflow and damage summation such as Miner's rule) need to be done to determine the total amount of fatigue damage and which cycle combinations cause that damage
 - Cycle counting is a means to reduce a complex load history into a number of events, which can be compared to the available constant amplitude test data

Fatigue Analysis in Workbench

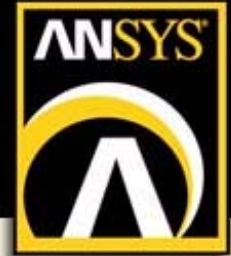

- **Non-constant amplitude, proportional loading**
 - The ANSYS Fatigue Module uses a “quick counting” technique to substantially reduce runtime and memory
 - In quick counting, alternating and mean stresses are sorted into bins before partial damage is calculated

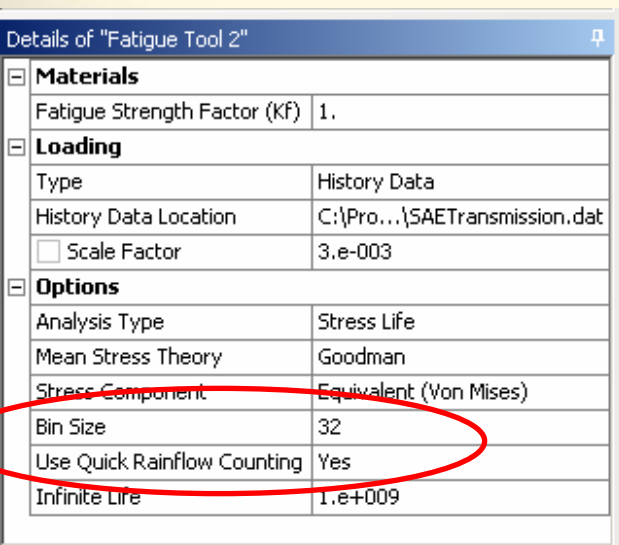

- Without quick counting, data is not sorted into bins until after partial damages are found
- The accuracy of quick counting is usually very good if a proper number of bins are used when counting

Fatigue Analysis in Workbench

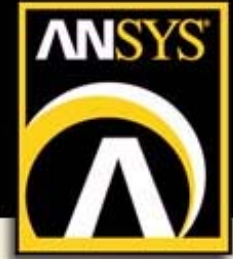

- **Non-constant amplitude, proportional loading**
 - **Bin size defines how many divisions the cycle counting history should be organized into**

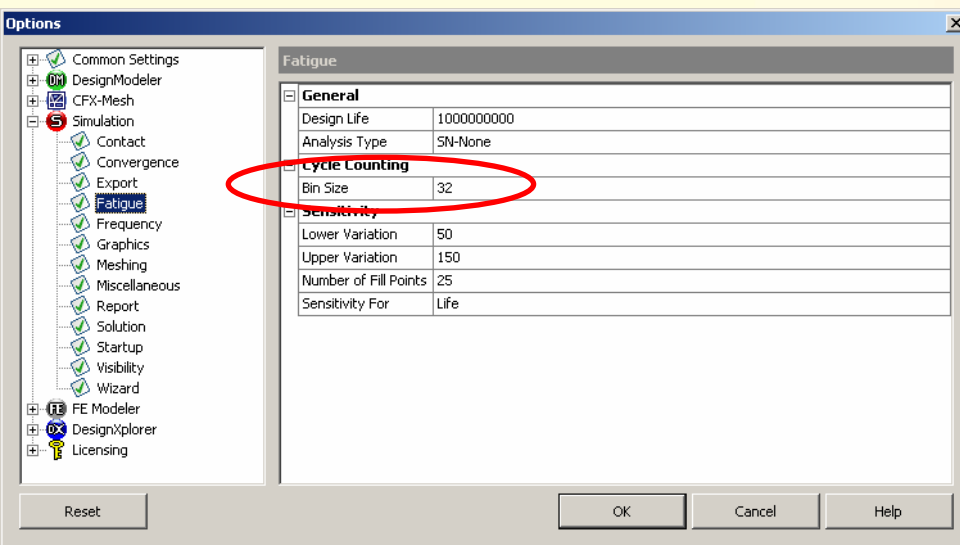

- **Strictly speaking, bin size specifies the number of divisions of the rainflow matrix**
- **A larger bin size has greater precision but will take longer to solve and use more memory**
- **Bin size defaults to 32, meaning that the Rainflow Matrix is 32 x 32 in dimension.**

Fatigue Analysis in Workbench

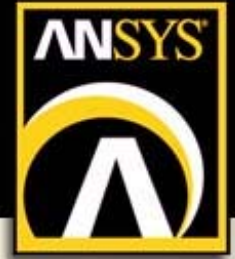

- **Non-constant amplitude, proportional loading**
 - For Stress Life, another available option when conducting a variable amplitude fatigue analysis is the ability to set the value used for infinite life
 - In constant amplitude loading, if the alternating stress is lower than the lowest alternating stress on the fatigue curve, the fatigue tool will use the life at the last point
 - This provides for an added level of safety because many materials do not exhibit an endurance limit

Fatigue Analysis in Workbench

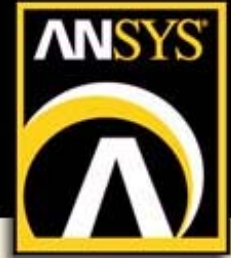

- **Non-constant amplitude, non-proportional loading**
 - Most general case and is similar to Constant Amplitude, non-proportional loading, but in this loading class there are more than 2 different stress cases involved that have no relation to one another
 - Not only is the spatial location of critical fatigue life unknown, but also unknown is what combination of loads cause the most damage
 - Thus, more advanced cycle counting is required such as path independent peak methods or multiaxial critical plane methods
 - Currently the ANSYS Fatigue Module does not support this type of fatigue loading

Fatigue Analysis in Workbench

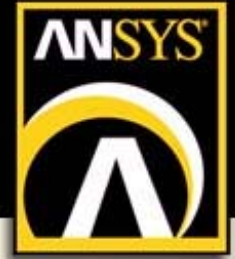

- ***Mean Stress Correction***

- Cyclic fatigue properties of a material are often obtained from completely reversed, constant amplitude tests
- Actual components seldom experience this pure type of loading, since some mean stress is usually present
- If the loading is other than fully reversed, a mean stress exists and may be accounted for by using a Mean Stress Correction

Fatigue Analysis in Workbench

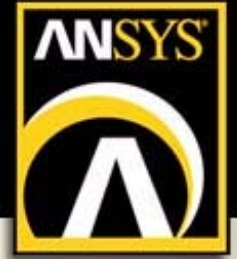

- ***Mean Stress Correction (Stress Life)***
 - ***Soderburg***
 - ***Goodman***
 - ***Gerber***
 - ***Mean Stress Curves***
 - ***Mean Stress Dependent***
 - ***Multiple r-ratio curves***
 - ***No Mean Stress Correction (None)***

Fatigue Analysis in Workbench

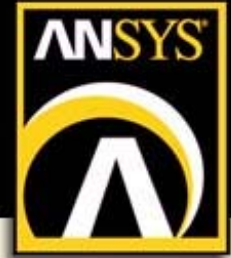

- **Mean Stress Correction (Stress Life)**

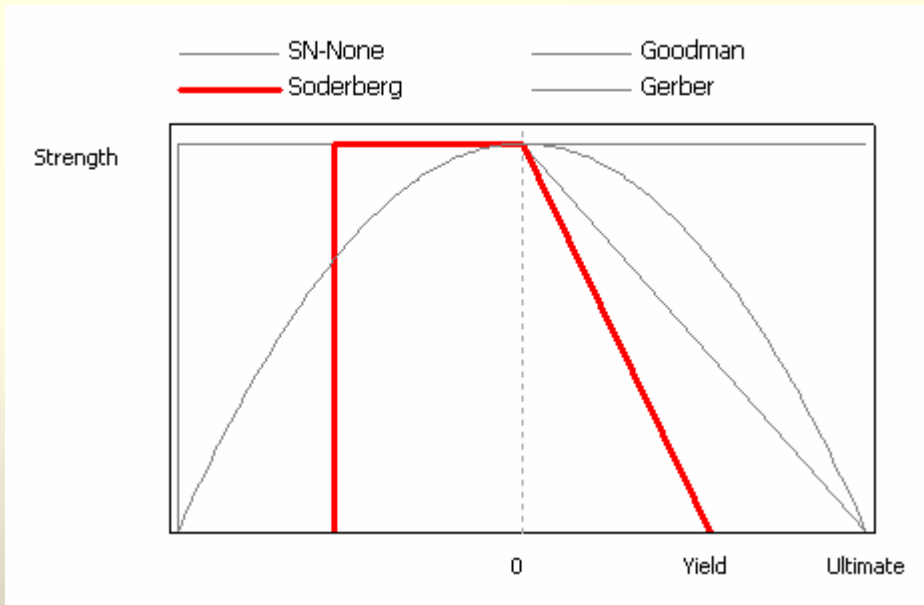

- **Soderberg**

- **Is usually overly conservative**
- **Soderberg theory is not bounded when using negative mean stresses**
 - **ANSYS Fatigue Module does bound the negative means stresses**
 - **Negative mean stress is capped to the yield stress**

$$\frac{\sigma_{Alternating}}{S_{Endurance_Limit}} + \frac{\sigma_{Mean}}{S_{Yield_Strength}} = 1$$

Fatigue Analysis in Workbench

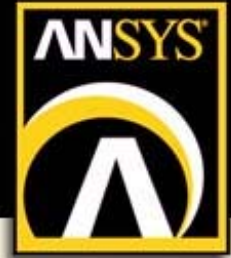

- **Mean Stress Correction (Stress Life)**

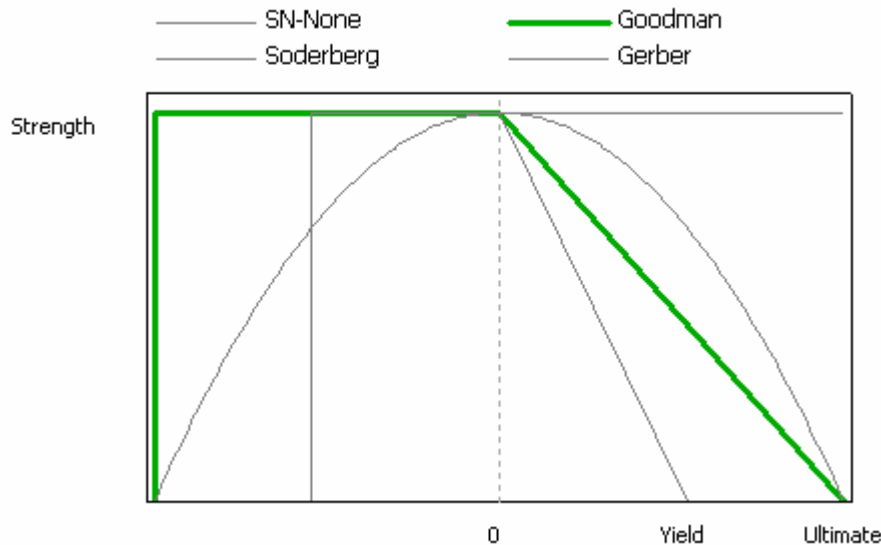

- **Goodman**

- **Most experimental data falls between Goodman and Gerber theories**
- **Goodman theory is usually a good choice for brittle materials**
- **Goodman theory is not bounded when using negative mean stresses**
 - **ANSYS Fatigue Module does bound the negative means stresses to the ultimate stress**

$$\frac{\sigma_{Alternating}}{S_{Endurance_Limit}} + \frac{\sigma_{Mean}}{S_{Ultimate_Strength}} = 1$$

Fatigue Analysis in Workbench

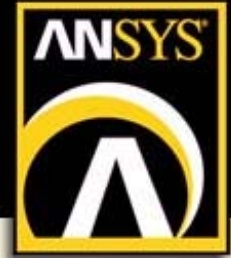

- **Mean Stress Correction (Stress Life)**

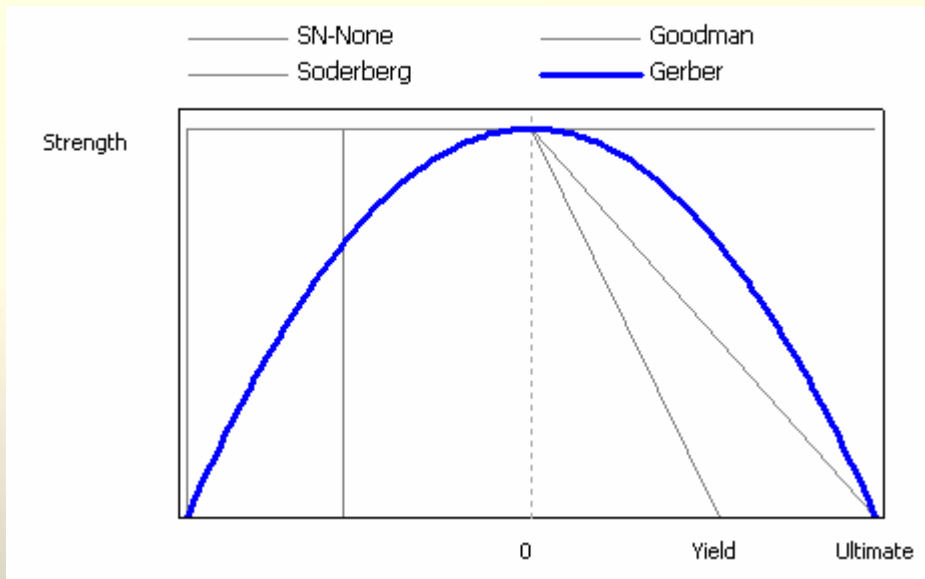

- **Gerber**

- **Most experimental data falls between Goodman and Gerber theories**
- **Gerber theory usually a good choice for ductile materials**
- **Gerber theory is bounded when using negative mean stresses**

$$\frac{\sigma_{Alternating}}{S_{Endurance_Limit}} + \left(\frac{\sigma_{Mean}}{S_{Ultimate_Strength}} \right)^2 = 1$$

Fatigue Analysis in Workbench

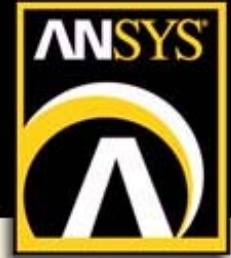

- **Mean Stress Correction (Stress Life)**

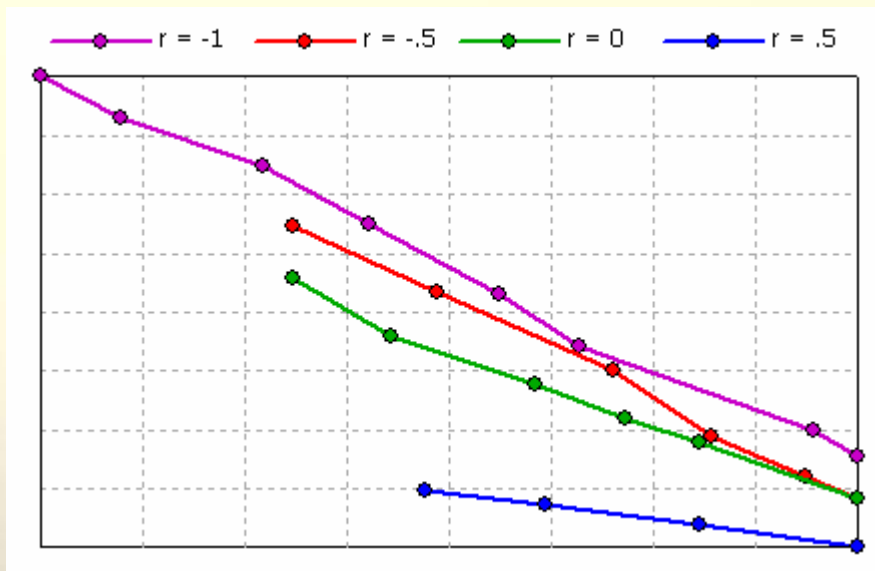

- **Mean Stress Curves**

- **Uses experimental fatigue data to account for mean stress effects**
- **Two Types Available**
 - Mean Stress Dependent
 - Multiple r-ratio curves
- **In general, it is not advisable to use an empirical mean stress theory if multiple mean stress data exists**

Fatigue Analysis in Workbench

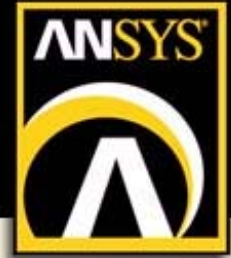

- **Mean Stress Correction (Strain Life)**

- **Morrow's method**

- **Modified Elastic term in the strain-life equation**
- **Consistent with observations that mean stress:**

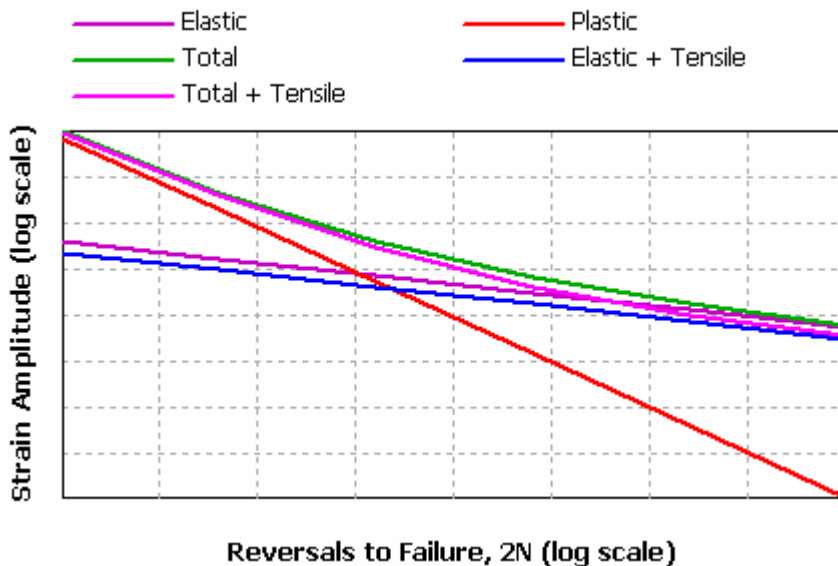

$$\frac{\Delta \varepsilon}{2} = \frac{\sigma_f' - \sigma_{Mean}}{E} (2N_f)^b + \varepsilon_f' (2N_f)^c$$

- **is significant at low values of plastic strain**
- **has little effect at high values of plastic strain**
- **Incorrectly predicts that the ratio of elastic to plastic strain is dependent on mean stress**

Fatigue Analysis in Workbench

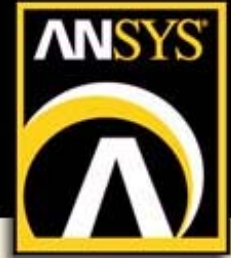

- **Mean Stress Correction (Strain Life)**
 - **Smith, Watson and Topper (SWT)**

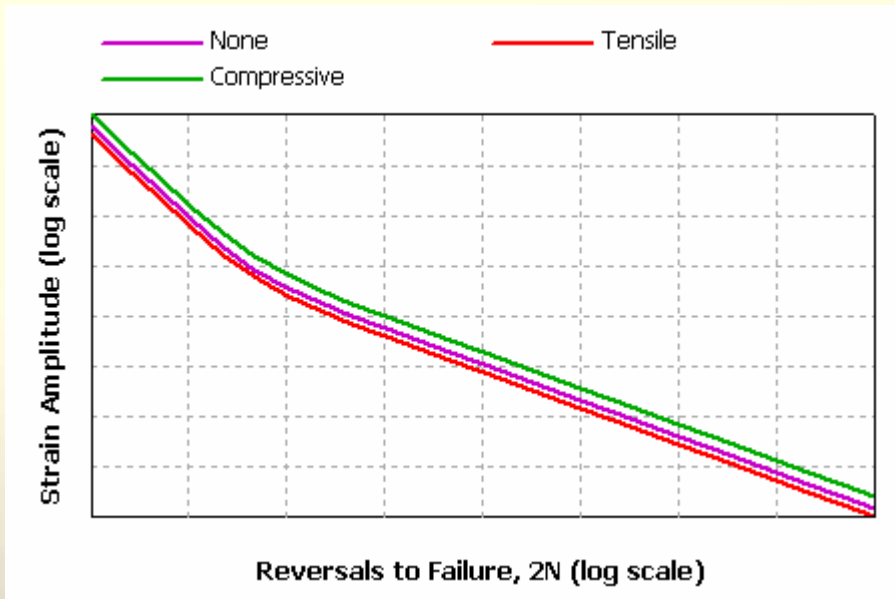

- **Use a different equation to account for the presence of mean stresses**
 - **It has the limitation that it is undefined for negative maximum stresses**
 - **The physical interpretation of this is that no fatigue damage occurs unless tension is present at some point during the loading**

$$\sigma'_{Maximum} \frac{\Delta \epsilon}{2} = \frac{(\sigma'_f)^2}{E} (2N_f)^{2b} + \sigma'_f \epsilon'_f (2N_f)^{b+c}$$

Fatigue Analysis in Workbench

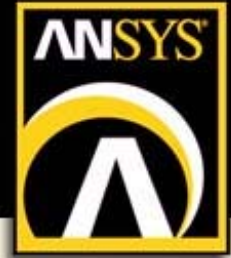

- ***Multiaxial Stress Correction***

- Experimental test data is mostly uniaxial whereas FE results are usually multiaxial
- At some point, stress must be converted from a multiaxial stress state to a uniaxial one
- In the ANSYS Fatigue Module:
 - Von-Mises, max shear, maximum principal stress, or any of the component stresses can be used to compare against the experimental uniaxial stress value
 - A “signed” Von-Mises stress may be chosen where the Von-Mises stress takes the sign of the largest absolute principal stress
 - This is useful to identify any compressive mean stresses since several of the mean stress theories treat positive and negative mean stresses differently.

Fatigue Analysis in Workbench

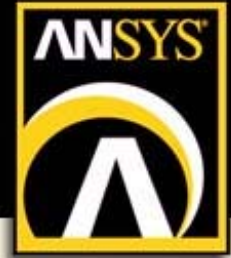

- ***Fatigue Modifications***

- Value of Infinite Life
- Fatigue Strength Factor
- Loading Scale Factor
- Interpolation Type (Stress Life)
 - Log-log
 - Semi-log
 - Linear

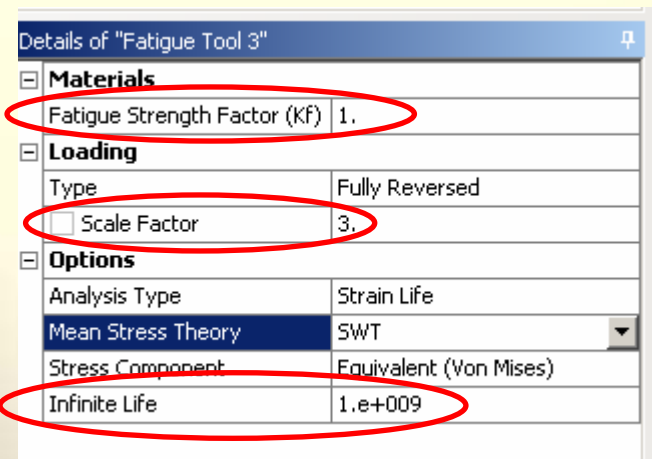

Fatigue Analysis in Workbench

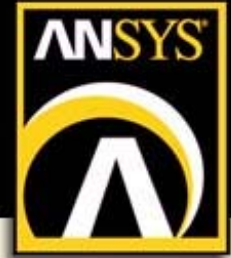

- **Value of Infinite Life (Stress Life)**
 - In constant amplitude loading, if the alternating stress is lower than the lowest alternating stress on the fatigue curve, the fatigue tool will use the life at the last point
 - This provides for an added level of safety because many materials do not exhibit an endurance limit
 - However, in non-constant amplitude loading, cycles with very small alternating stresses may be present and may incorrectly predict too much damage if the number of the small stress cycles is high enough
 - To help control this, the user can set the infinite life value that will be used if the alternating stress is beyond the limit of the SN curve
 - Setting a higher value will make small stress cycles less damaging if they occur many times
 - The rainflow and damage matrix results can be helpful in determining the effects of small stress cycles in your loading history

Fatigue Analysis in Workbench

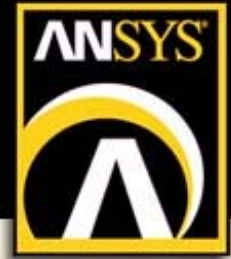

- **Value of Infinite Life (Stress Life)**

Rainflow matrix for a given load history.

Resulting Damage Matrix when the Value of Infinite Life is equal to 10^6 cycles. Total damage is calculated to be 0.19.

Resulting Damage Matrix when the Value of Infinite Life is equal to 10^9 cycles. Total damage is calculated to be 0.12 (37% less damage).

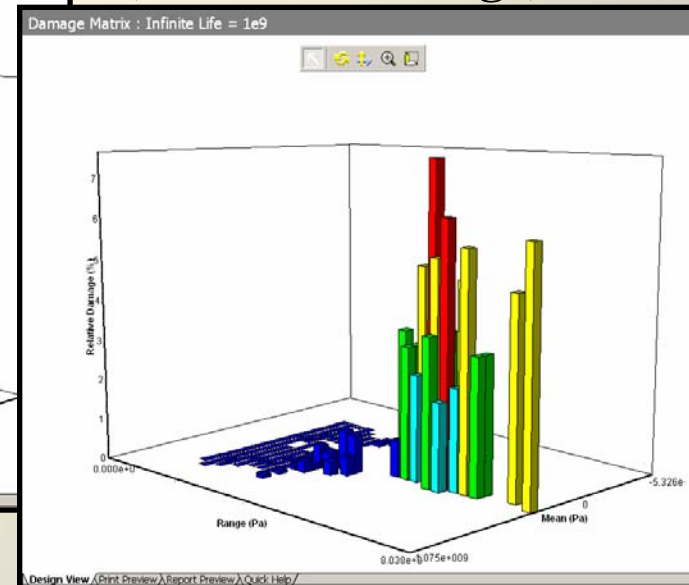
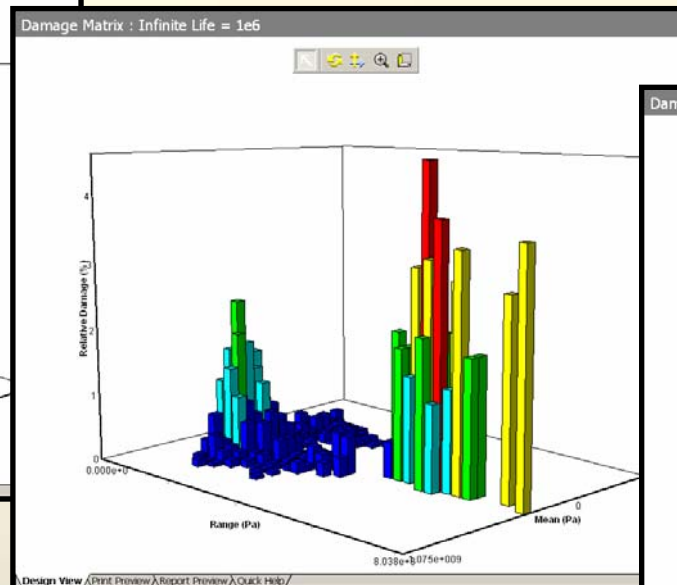
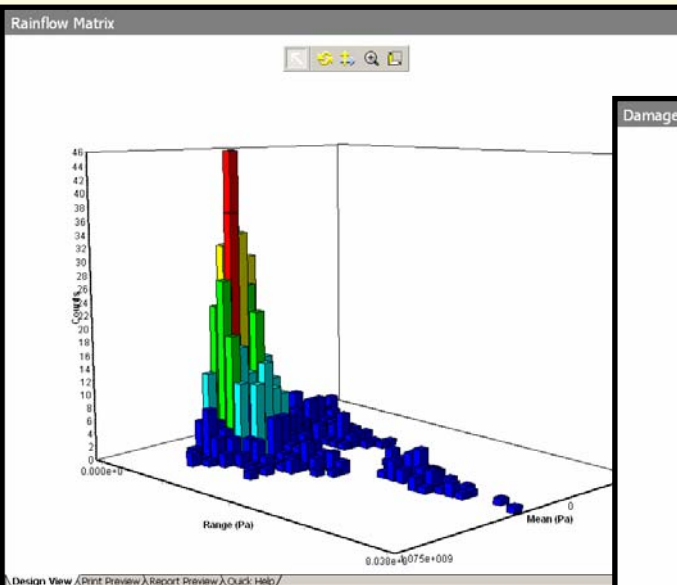

Fatigue Analysis in Workbench

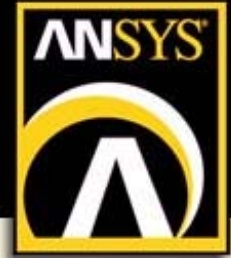

- **Fatigue Strength Factor**
 - *Modification factors to account for the differences between the in service part from the as tested conditions*
 - *In design handbooks, the fatigue alternating stress is usually divided by this modification factor*
 - *In the ANSYS Fatigue Module, the Fatigue Strength Factor (K_f) reduces the fatigue strength and must be less than one*
 - *Note that this factor is applied to the alternating stress only*
 - *Does not affect the mean stress.*
 - *Same as values from Handbooks (Example: Shigley) but all factors combined into one value*

Fatigue Analysis in Workbench

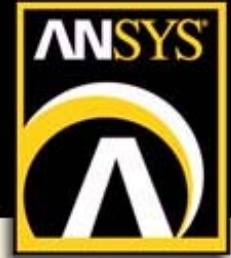

- **Loading Scale Factor**
 - *Loading Scale Factor that will scale all stresses, both alternating and mean by the specified value*
 - *This value may be parameterized*
 - *Applying a scale factor is useful to avoid having to solve the static model again to see the effects of changing the magnitude of the FEM loads*
 - *In addition, this factor may be useful to convert a non-constant amplitude load history data into the appropriate values*

Example:

$$\left(\frac{1 \text{ FEM load}}{1000 \text{ lbs}} \right) \times \left(\frac{1000 \text{ lbs}}{200 \text{ strain gauge}} \right) = \left(\frac{1 \text{ FEM load}}{200 \text{ strain gauge}} \right) = \text{Needed Load Scale Factor}$$

Fatigue Analysis in Workbench

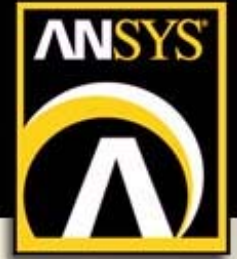

- **Interpolation Type (Stress Life)**
 - When the stress life analysis needs to query the S-N curve, almost assuredly the data will not be available at the same stress point as the analysis has produced; hence the stress life analysis needs to interpolate the S-N curve to find an appropriate value
 - Three interpolations are available
 - Log-log
 - Semi-log
 - Linear
 - Results will vary due to the interpolation method used

Fatigue Analysis in Workbench

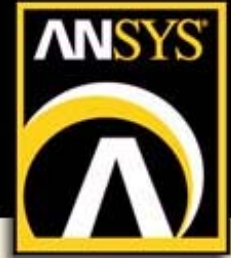

- **Fatigue Results**

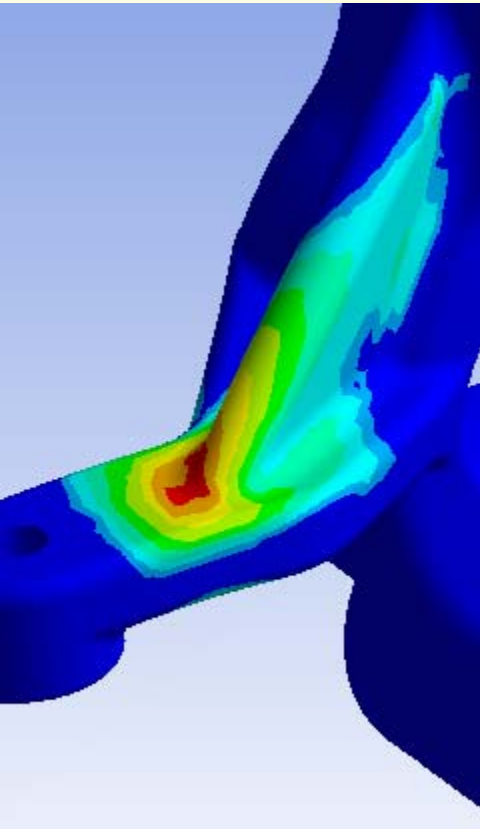

- Calculations and results can be dependent upon the type of fatigue analysis
- Results that are common to both types of fatigue analyses are listed below:
 - Fatigue Life
 - Fatigue Damage at a specified design life
 - Fatigue Factor of Safety at a specified design life
 - Stress Biaxiality
 - Fatigue Sensitivity Chart
 - Rainflow Matrix output (Beta for Strain Life at 10.0)
 - Damage Matrix output (Beta for Strain Life at 10.0)
- Results that are only available for Stress Life are:
 - Equivalent Alternating Stress
- Results that are only available for Strain Life are:
 - Hysteresis

Fatigue Analysis in Workbench

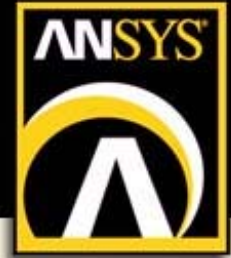

- **Fatigue life**
 - Shows the available life for the given fatigue analysis
 - Result contour plot, which can be over the whole model or scoped
 - This, and any contour result, may be exported to a tab-delimited text file by a right mouse button click on the result
 - If loading is of constant amplitude, this represents the number of cycles until the part will fail due to fatigue
 - If loading is non-constant (i.e. a load history), this represents the number of loading blocks until failure
 - If a given load history represents one hour of loading and the life was found to be 24,000, then the expected model life would be 1,000 days
 - In a Stress Life analysis with constant amplitude, if the equivalent alternating stress is lower than the lowest alternating stress defined in the S-N curve, the life at that point will be used.

Fatigue Analysis in Workbench

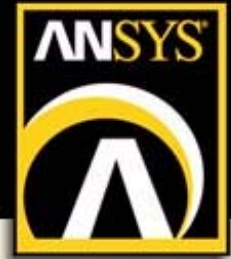

- **Fatigue Life**

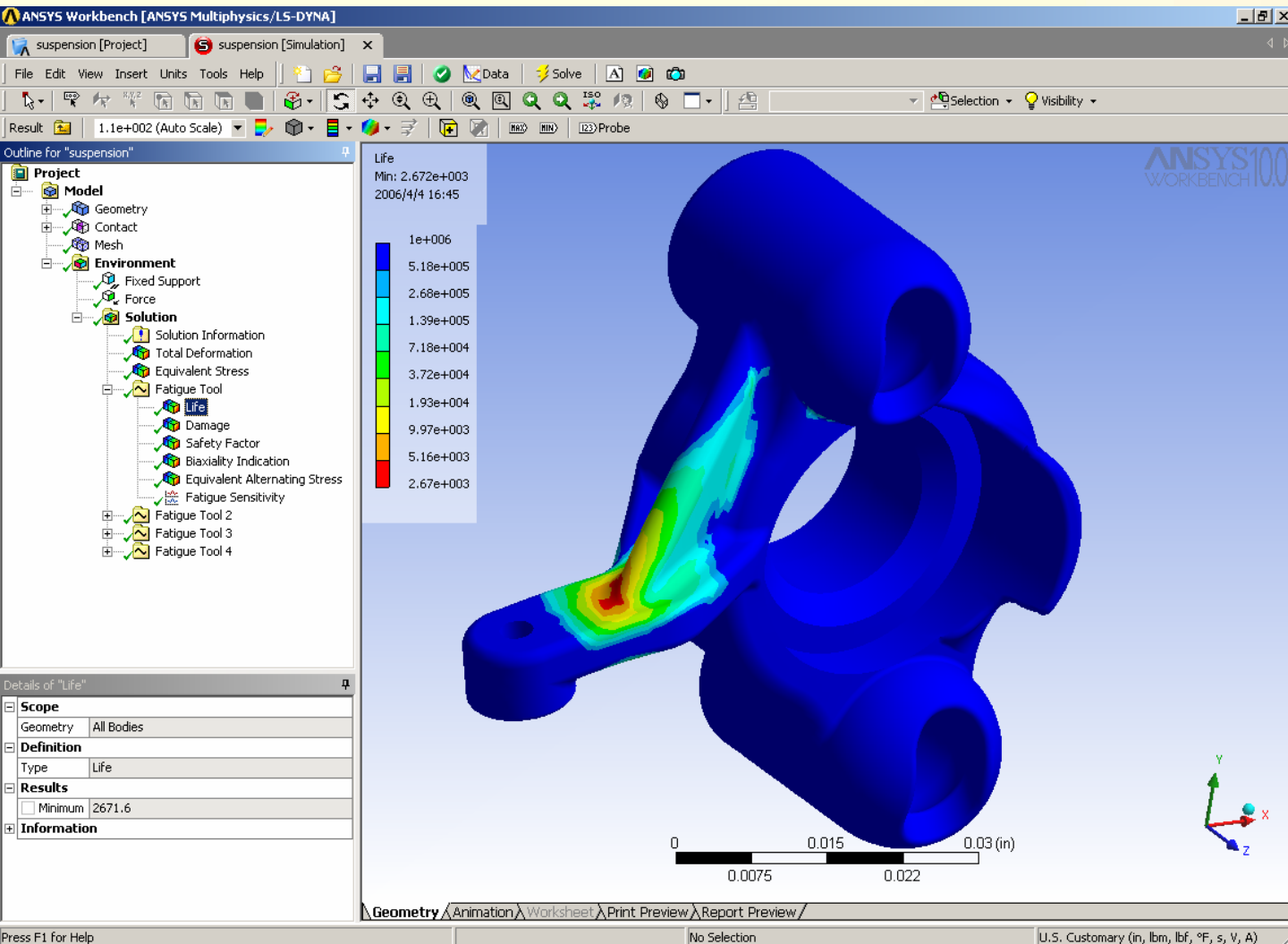

Fatigue Analysis in Workbench

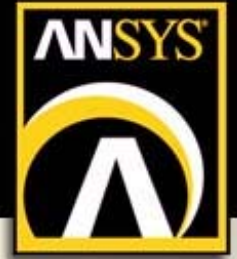

- **Fatigue Damage at a Design Life**
 - **Fatigue damage is defined as the design life divided by the available life**
 - **This result may be scoped**
 - **The default design life may be set through the Control Panel**
 - **For Fatigue Damage, values greater than 1 indicate failure before the design life is reached**

Fatigue Analysis in Workbench

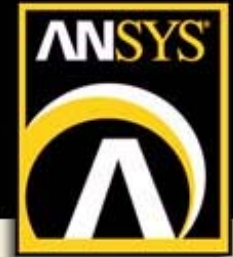

- **Fatigue Damage**

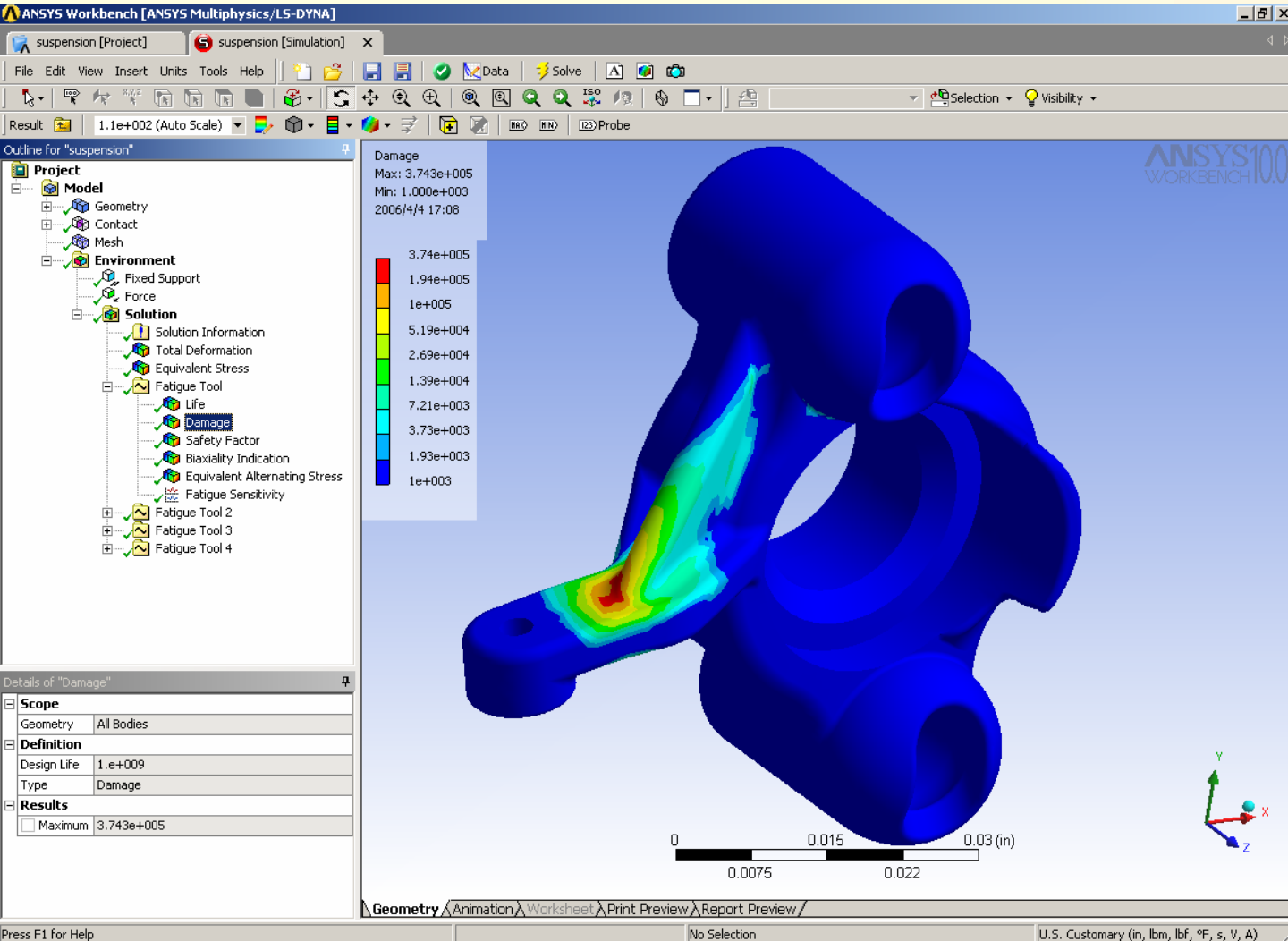

Fatigue Analysis in Workbench

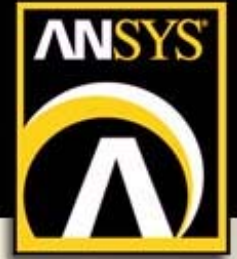

- **Fatigue Factor of Safety at a Design Life**
 - **Contour plot of the factor of safety with respect to a fatigue failure at a given design life**
 - **Maximum Factor of Safety displayed is 15**
 - **Like damage and life, this result may be scoped**
 - **For Fatigue Safety Factor, values less than one indicate failure before the design life has been reached**

Fatigue Analysis in Workbench

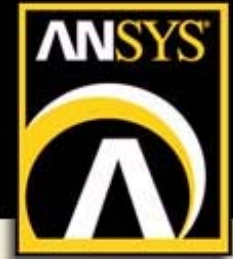

- **Fatigue Factor of Safety at a Design Life**

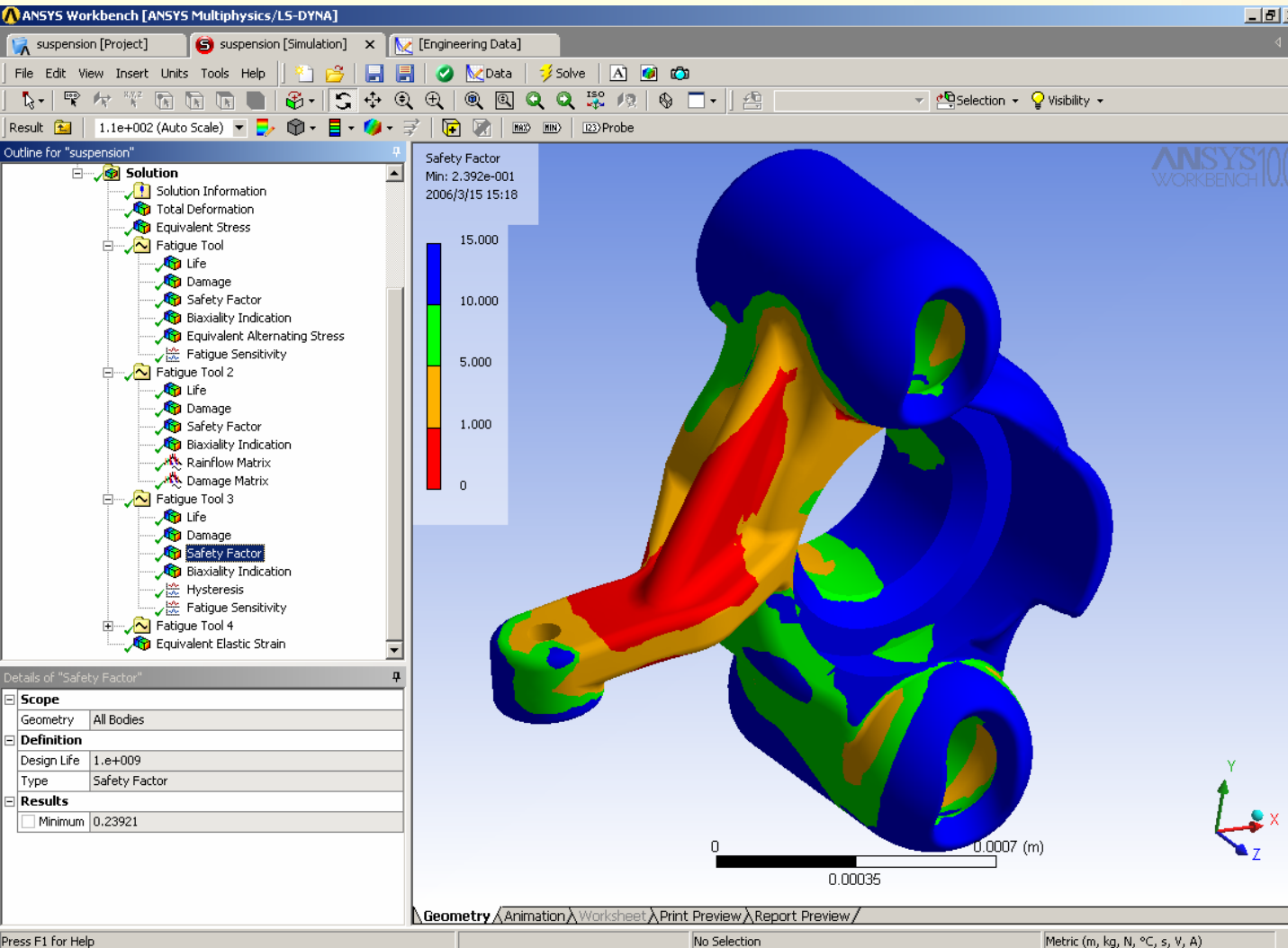

Fatigue Analysis in Workbench

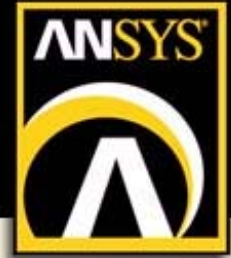

- **Stress Biaxiality Indication**
 - Fatigue material properties are typically based on uniaxial stresses
 - Real world stress states are usually multiaxial
 - This fatigue result gives the user some indication of the stress state over the model and how to interpret the results
 - Biaxiality indication is defined as the smaller in magnitude principal stress divided by the larger principal stress with the principal stress nearest zero ignored
 - **Stress Biaxiality Indication Values:**
 - Biaxiality of zero corresponds to uniaxial stress
 - Biaxiality of -1 corresponds to pure shear
 - Biaxiality of 1 corresponds to a pure biaxial state

Fatigue Analysis in Workbench

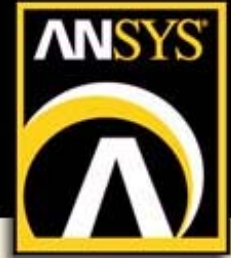

- **Stress Biaxiality Indication**

- Majority of this model is under a pure uniaxial stress, with parts exhibiting both pure shear and nearly pure biaxiality
- Comparing biaxiality with safety factor, the most damaged point occurs at a point of nearly uniaxial stress

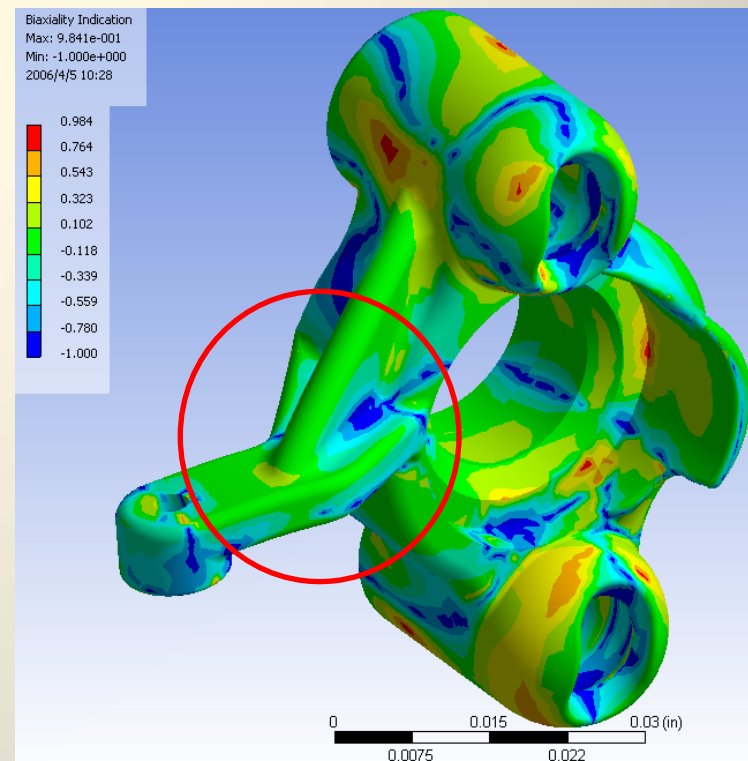
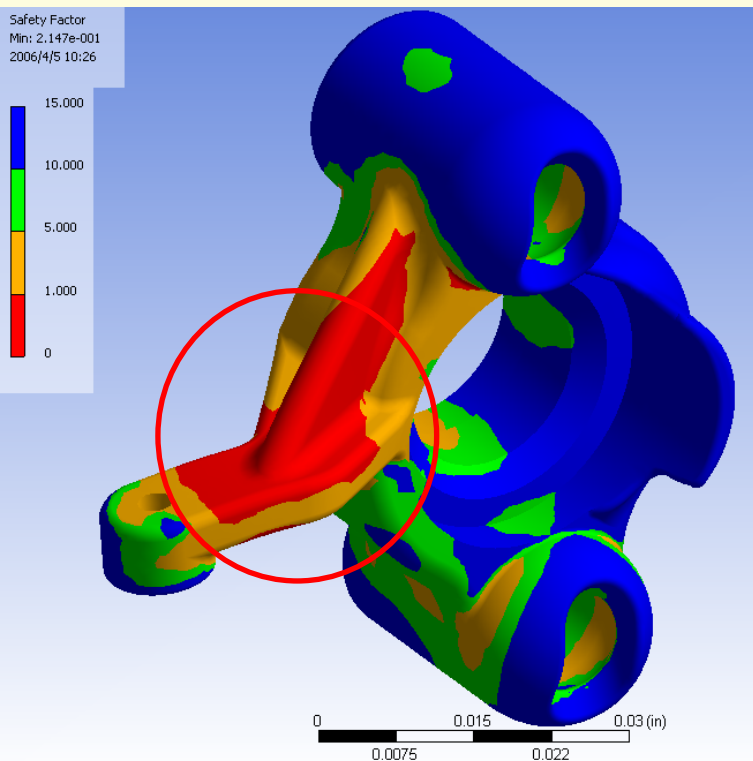

Fatigue Analysis in Workbench

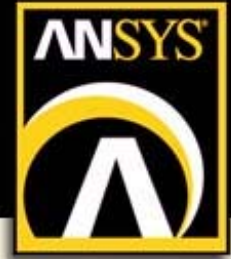

- **Stress Biaxiality Indication**
 - In the preceding example, if the most damaged spot was under pure shear, then it would be desirable to use S-N data collected through torsional loading, if such data was available
 - Unfortunately, collecting experimental data under different loading conditions is cost prohibitive and not often done

Fatigue Analysis in Workbench

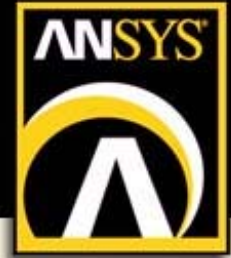

- **Stress Biaxiality Indication**

- For non-proportional fatigue loading, there are multiple stress states and thus there is no single stress biaxiality at each node

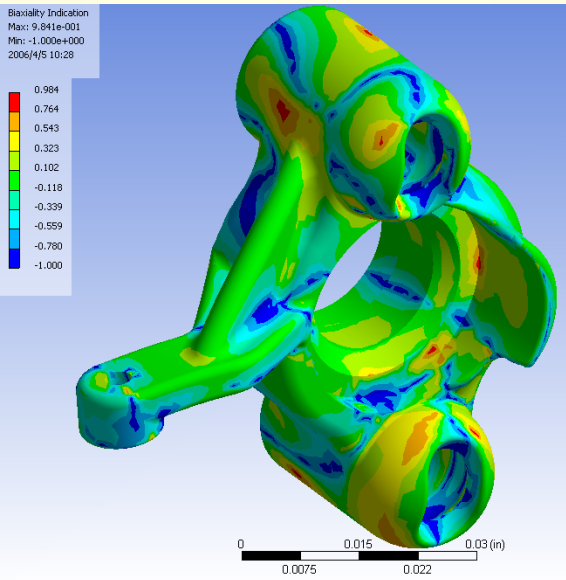

- The user may select either to view the average or standard deviation of stress biaxiality
- The average value may be interpreted as above and in combination with the standard deviation, the user can get a measure of how the stress state changes at a given location
- Thus a small standard deviation indicates a condition where the loading is near proportional while a larger deviation indicates change in the direction of the principal stress vectors
- This information can be used to give the user additional confidence in his results or whether more in depth fatigue analysis is needed to account for non-proportionality

Fatigue Analysis in Workbench

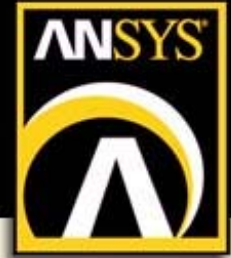

- Fatigue Sensitivity Chart
 - Shows how the fatigue results change with loading at the critical location on the model
 - User specifies:

| Details of "Fatigue Sensitivity 3" | |
|------------------------------------|------------|
| General | |
| GeometrySelection | All Bodies |
| SensitivityFor | Life |
| LowerVariation | 50. % |
| UpperVariation | 150. % |
| NumFillPoints | 25 |
| AxisScaleType | Linear |

- Sensitivity for life, damage, or factor of safety
- Number of fill points
- Load variation limits
 - Negative variations are allowed to see the effects of a possible negative mean stress if the loading is not totally reversed
 - Linear, Log-X, Log-Y, or Log-Log scaling

Fatigue Analysis in Workbench

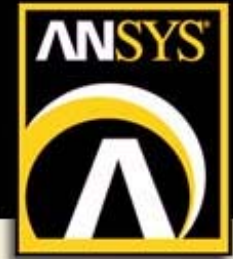

Fatigue Sensitivity Chart

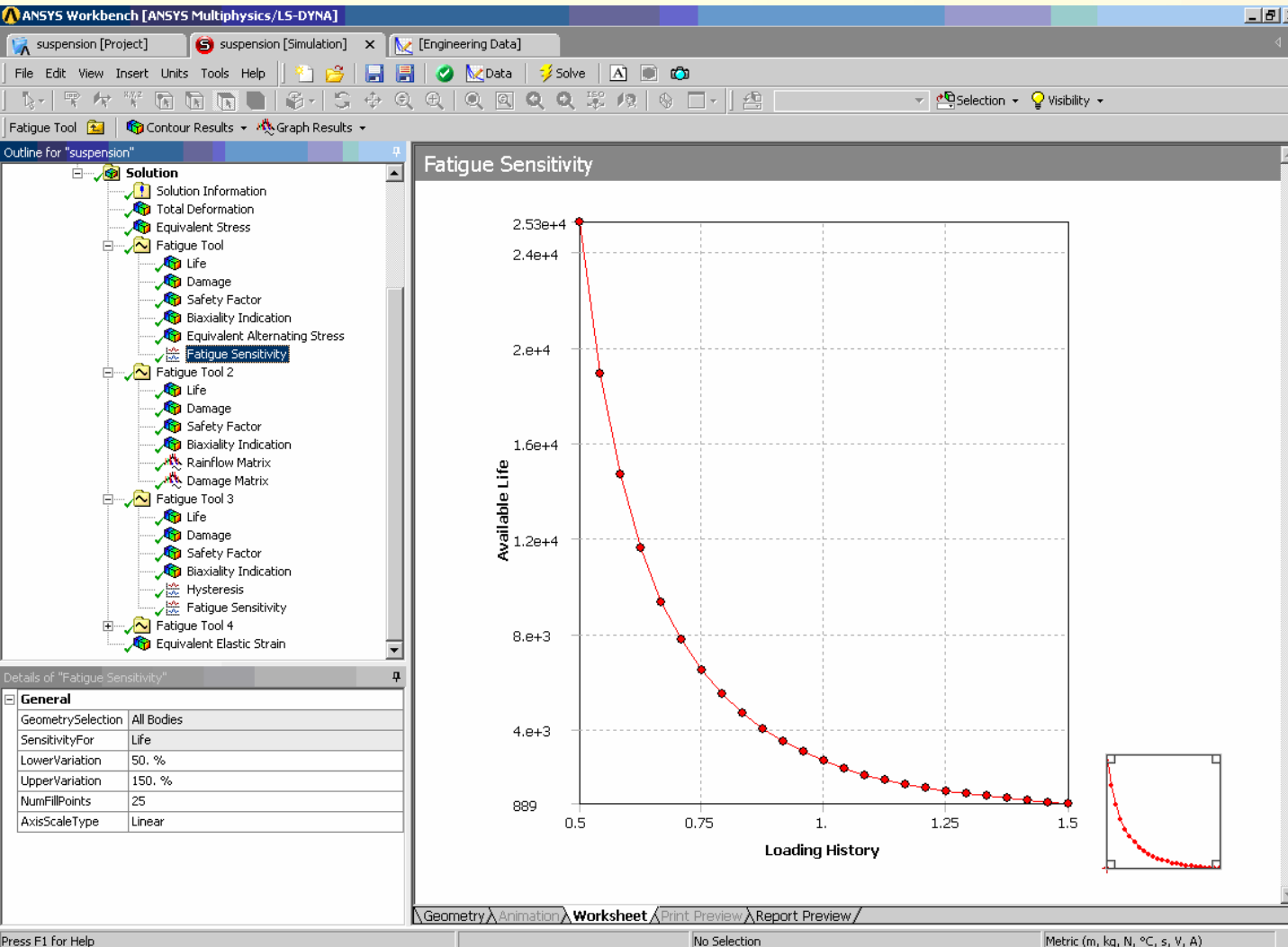

Fatigue Analysis in Workbench

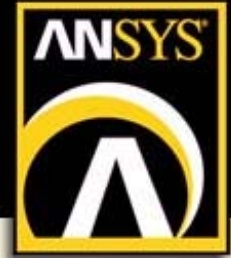

- **Rainflow Matrix Output (Beta, Strain Life, 10.0)**
 - Shows the rainflow matrix at the critical location
 - Only applicable for non-constant amplitude loading where rainflow counting is needed
 - This result may be scoped
 - 3-D histogram where alternating and mean stress is divided into bins and plotted
 - Z-axis corresponds to the number of counts for a given alternating and mean stress bin
 - This result gives the user a measure of the composition of a loading history
 - Such as if most of the alternating stress cycles occur at a negative mean stress

Fatigue Analysis in Workbench

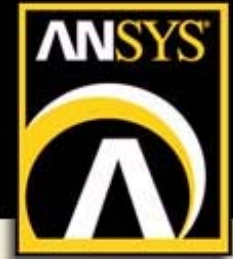

- Rainflow Matrix Output (Beta, Strain Life, 10.0)

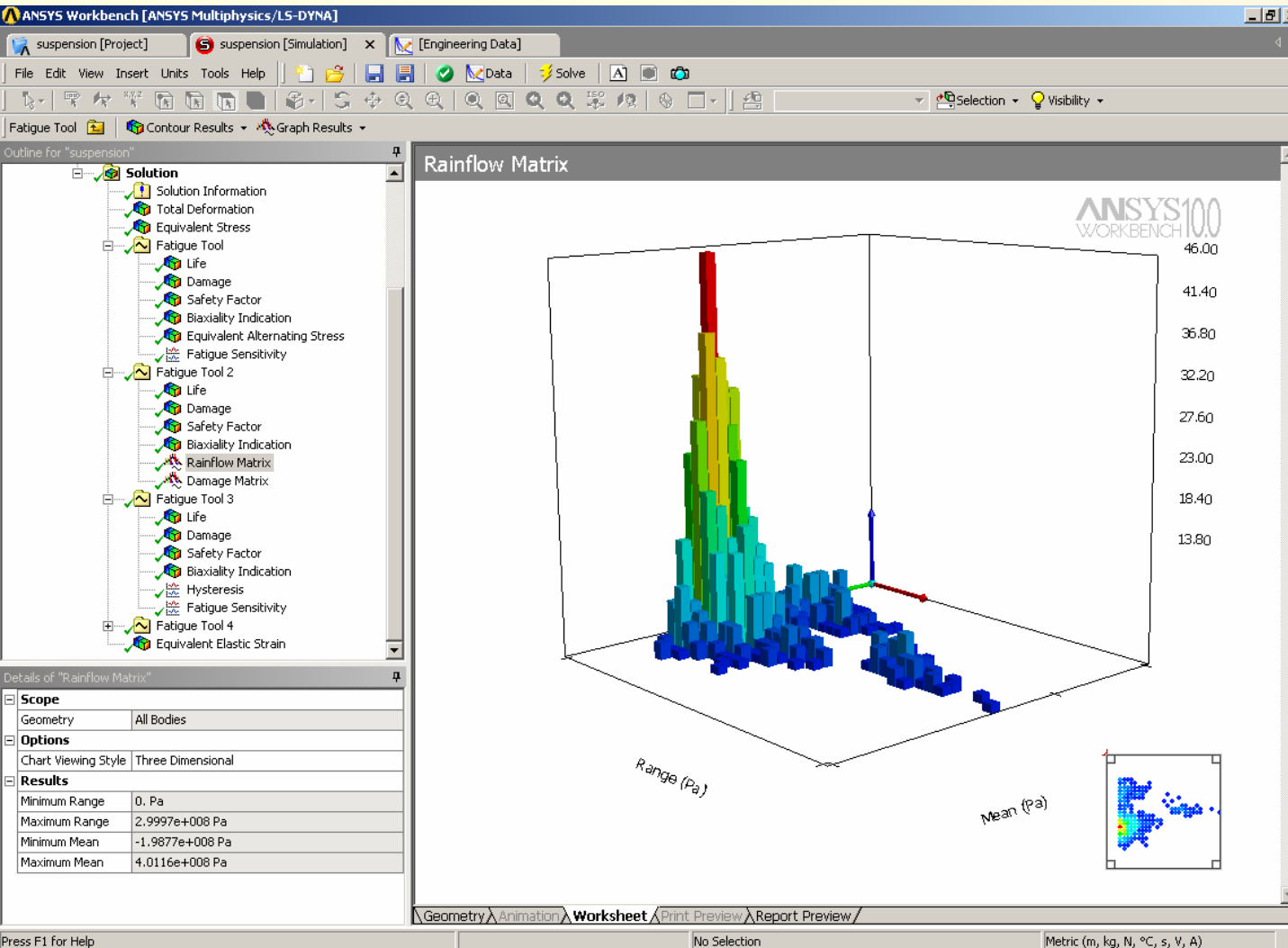

Fatigue Analysis in Workbench

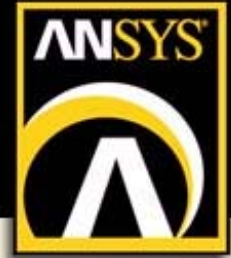

- **Damage Matrix Output (Beta for Strain Life at 10.0)**
 - Shows the damage matrix at the critical location on the model
 - This result is only applicable for non-constant amplitude loading where rainflow counting is needed
 - This result may be scoped
 - 3-D histogram where alternating and mean stress is divided into bins and plotted
 - Z-axis corresponds to the percent damage that each of the Rainflow bin's cause
 - Similar to the rainflow matrix except that the percent damage that each of the Rainflow bin's cause is plotted on the Z-axis This result gives the user a measure of the composition of what is causing the most damage
 - Such as if most of the counts occur at the lower stress amplitudes, but most of the damage occurs at the higher stress amplitudes

Fatigue Analysis in Workbench

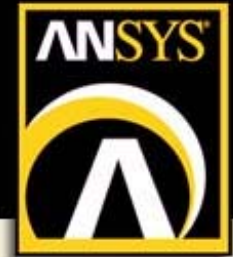

- **Damage Matrix Output (Beta for Strain Life at 10.0)**

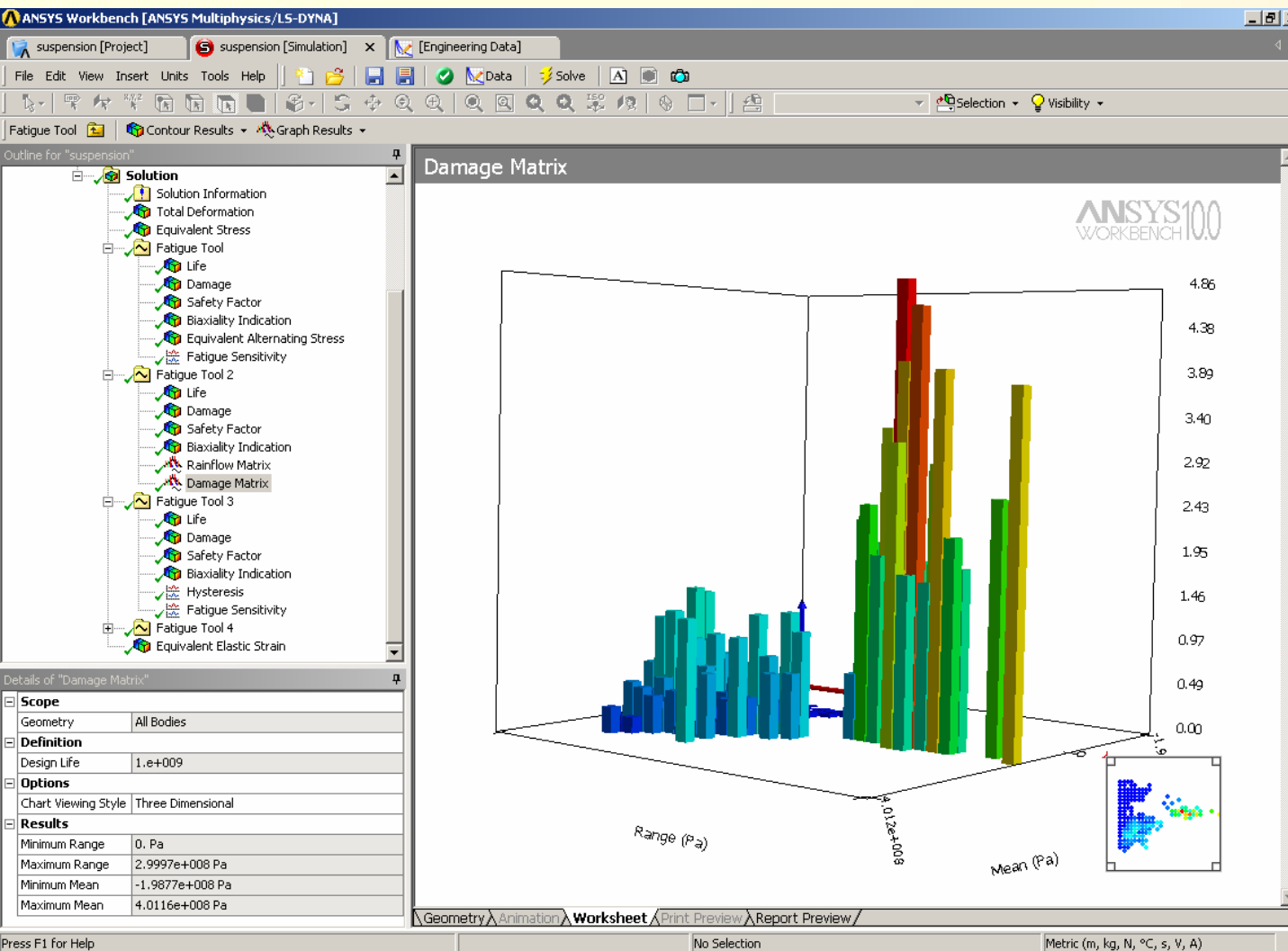

Fatigue Analysis in Workbench

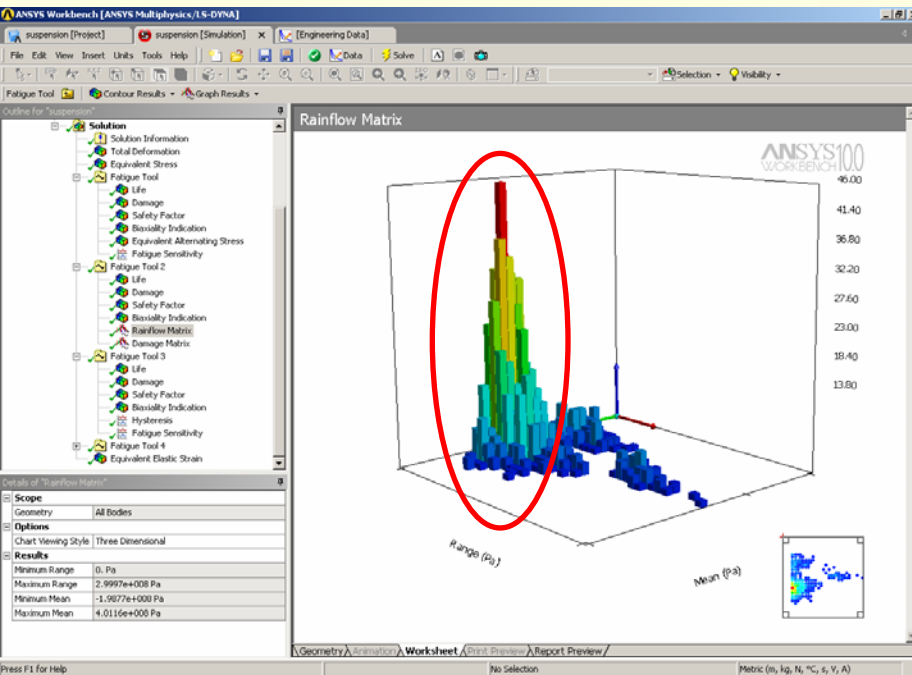
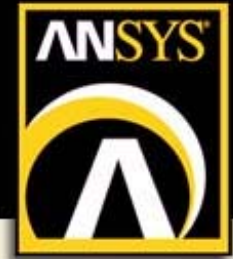

Rainflow Matrix

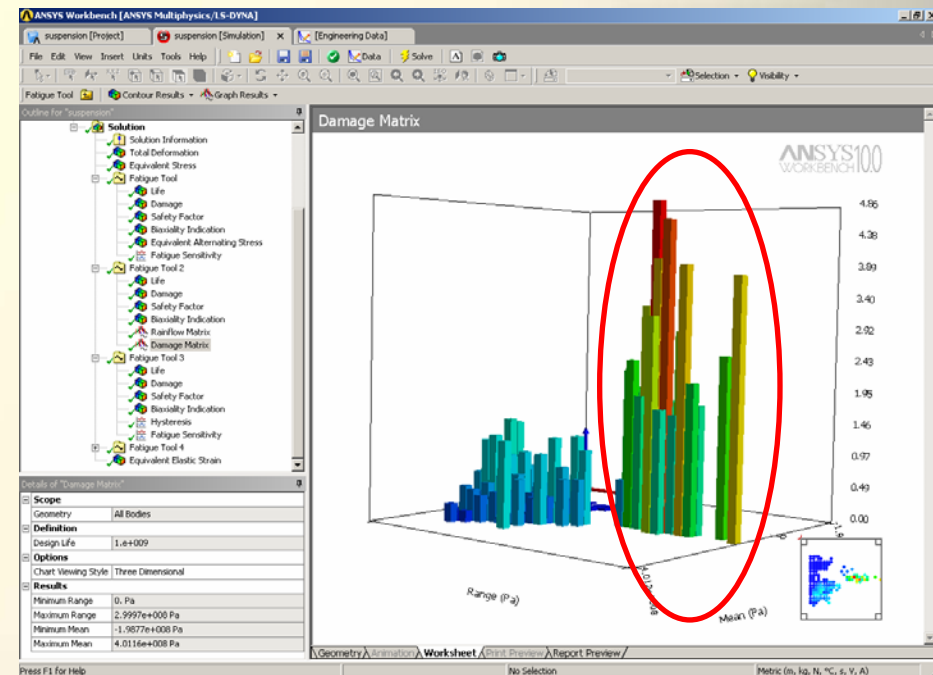

Damage Matrix

In this particular case although most of the counts occur at the lower stress amplitudes, most of the damage occurs at the higher stress amplitudes

Fatigue Analysis in Workbench

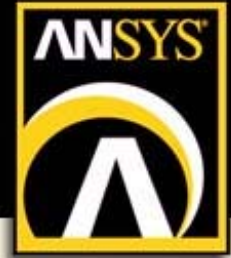

- **Equivalent Alternating Stress (Stress Life Only)**
 - **Stress Life always needs to query an SN curve to relate the fatigue life to the stress state**
 - **“Equivalent alternating stress” is the stress used to query the fatigue SN curve after accounting for fatigue loading type, mean stress effects, multiaxial effects, and any other factors in the fatigue analysis**
 - **Equivalent alternating stress is the last calculated quantity before determining the fatigue life**
 - **This result is not applicable to Stress life with non-constant amplitude fatigue loading due to the fact multiple SN queries per location are required and thus no single equivalent alternating stress exists**
 - **This result is not applicable to Strain Life**

Fatigue Analysis in Workbench

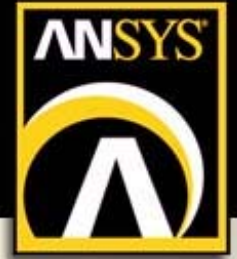

- **Equivalent Alternating Stress (Stress Life Only)**
 - **The usefulness of this result is that in general it contains all of the fatigue related calculations independent of any fatigue material properties**
 - **Note that some mean stress theories use static material properties such as tensile strength so Equivalent Alternating Stress may not be totally devoid of material properties**

Fatigue Analysis in Workbench

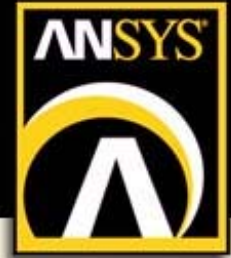

- **Equivalent Alternating Stress (Stress Life Only)**
 - **Equivalent Alternating Stress may be useful in a variety of situations:**
 - **Instead of possible security issues with proprietary material stress life properties, an engineer may be given an “equivalent alternating stress” design criteria.**
 - **The equivalent alternating stress may be exported to a 3rd party or “in house” fatigue code that performs specialized fatigue calculations based on the industry specific knowledge.**
 - **An engineer can perform a comparative analysis among a variety of designs using a result type (stress) that he may feel more comfortable with.**
 - **A part can be geometrically optimized with respect to fatigue without regard to the specific material or finishing operations that are going to be used for the final product**

Fatigue Analysis in Workbench

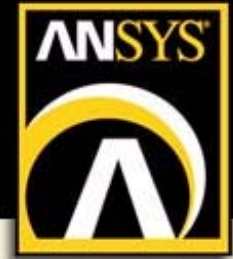

Equivalent Alternating Stress (Stress Life Only)

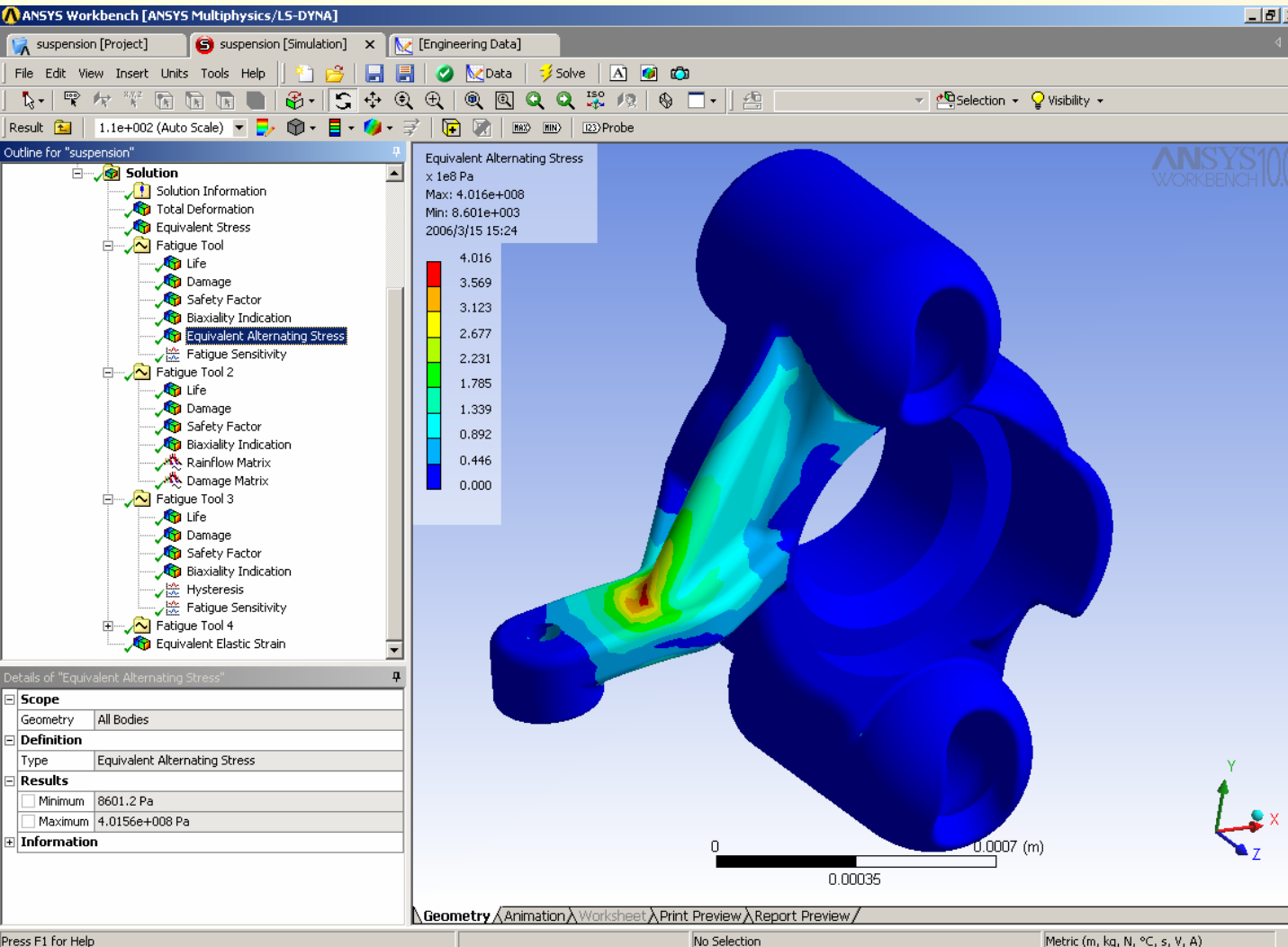

Fatigue Analysis in Workbench

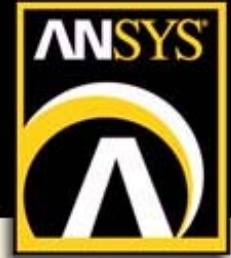

- **Hysteresis Result for Strain Life**
 - The Hysteresis result plots the local elastic-plastic response at the critical location
 - In strain-life fatigue, although the finite element response may be linear, the local elastic/plastic response may not be linear
 - The Neuber correction is used to determine the local elastic/plastic response given a linear elastic input
 - Repeated loading will form closed hysteresis loops as a result of this nonlinear local response
 - Constant amplitude analysis a single hysteresis loop is created
 - Non-constant amplitude analysis numerous loops may be created via rainflow counting
 - This result may be scoped
 - Hysteresis helps you understand the true local response which may not be easy to infer

Fatigue Analysis in Workbench

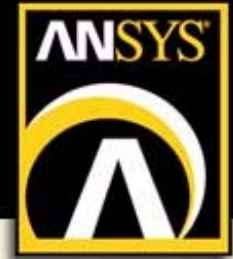

Hysteresis Result for Strain Life

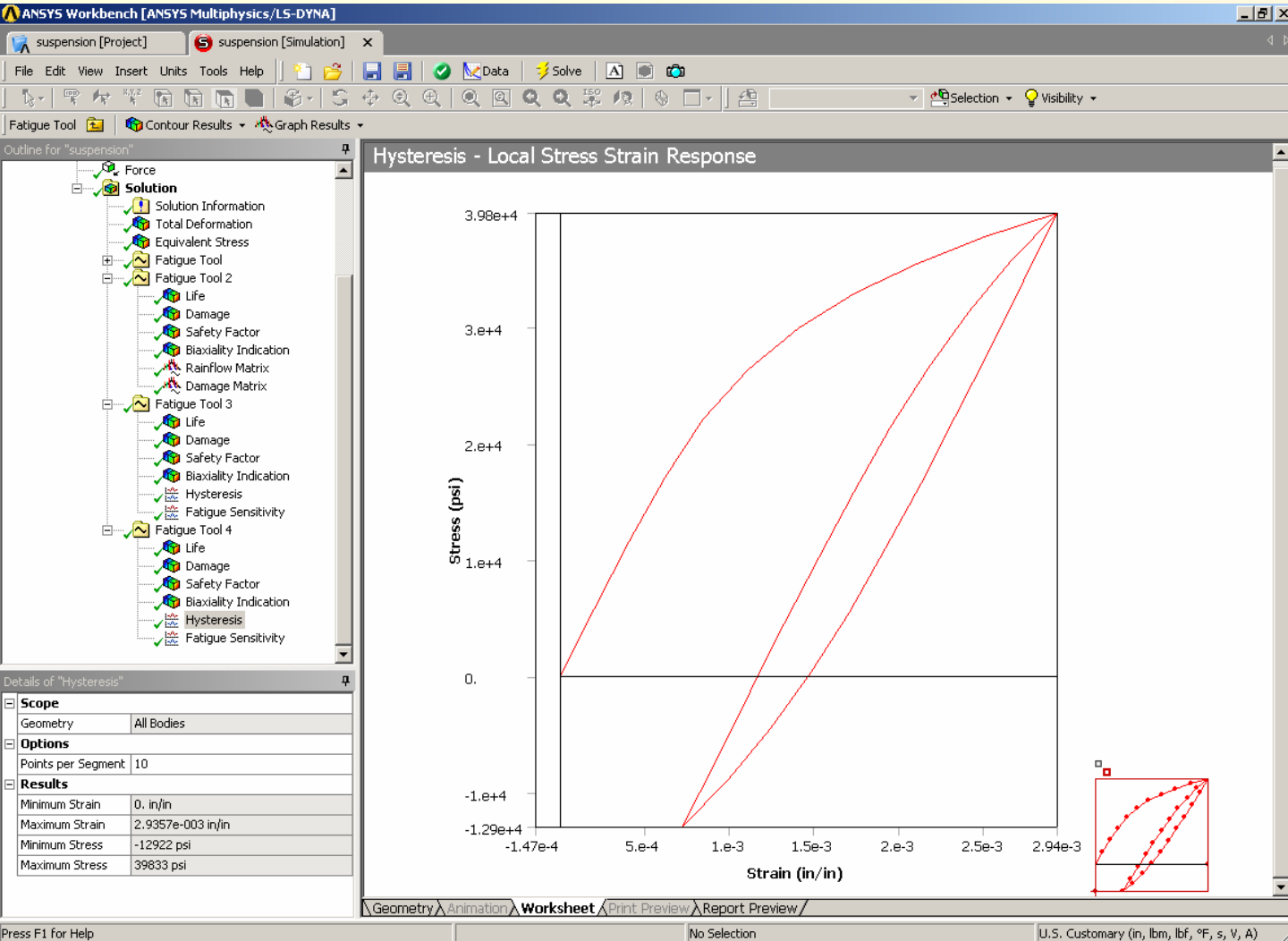

Working with Legacy Models

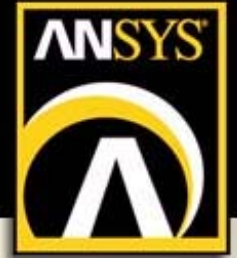

- Question:
What if you have a legacy model and wish to perform a Fatigue Analysis?
- Answer:
FE Modeler

Working with Legacy Models

Initial Mesh in FE Modeler

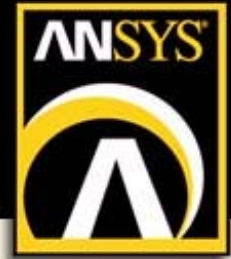

ANSYS Workbench [ANSYS Multiphysics]

[Project] | crankshaft [FE Model] | [Simulation]

File View Insert Tools Help | Export | Print | Print Preview | Target System: ANSYS | Component: Data | Deformed

Initial Geometry | New Target Configuration | Convert to NURBS Format

Mesh Update

Outline for "crankshaft"

- Project
 - Import Summary
 - Generate Data
 - Element Types (2)
 - 10 Node Quadratic Tetrahedron
 - General Spring Damper
 - Bodies (1)
 - Materials (1)
 - Spring Properties (1)
 - Components (5)
 - CMRX
 - Face1
 - Face2
 - Face3
 - Face4
 - Geometry
 - Skin detection tool
 - Initial Geometry
 - Part
 - Target Configuration

Data View

| Mesh Data | |
|--------------------|-----------------------|
| Number of Elements | 22474 |
| Description | 10 Node Tetrahedra... |
| ANSYS Name | Solid187 |

0.00 22.50 45.00 67.50 90.00

Current selection: 0 elements (0 nodes) Metric (mm, kg, N, °C, s, mV, mA)

Working with Legacy Models

Initial Configuration in FE Modeler

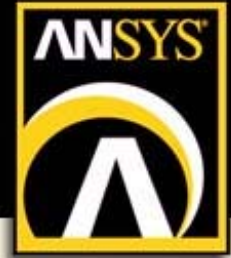

The screenshot displays the ANSYS Workbench [ANSYS Multiphysics] interface. The main window shows a 3D model of a crankshaft. The left sidebar contains the Project Outline for "crankshaft", which includes the following items:

- Project
 - Import Summary
 - Generate Data
 - Element Types (2)
 - 10 Node Quadratic Tetrahedron
 - General Spring Damper
 - Bodies (1)
 - Materials (1)
 - Spring Properties (1)
 - Components (5)
 - CMRX
 - Face1
 - Face2
 - Face3
 - Face4
 - Geometry
 - Skin detection tool
 - Initial Geometry
 - Part
 - Target Configuration

The Data View panel at the bottom left shows the following statistics:

| Definition | |
|-----------------------|-----|
| Target Configurations | 1 |
| Parts | 1 |
| Bodies | 1 |
| Faces | 73 |
| Edges | 161 |
| Vertice | 89 |

The bottom status bar indicates: Current selection: 0 elements (0 nodes) Metric (mm, kg, N, °C, s, mV, mA)

Working with Legacy Models

Transfer to Design Simulation

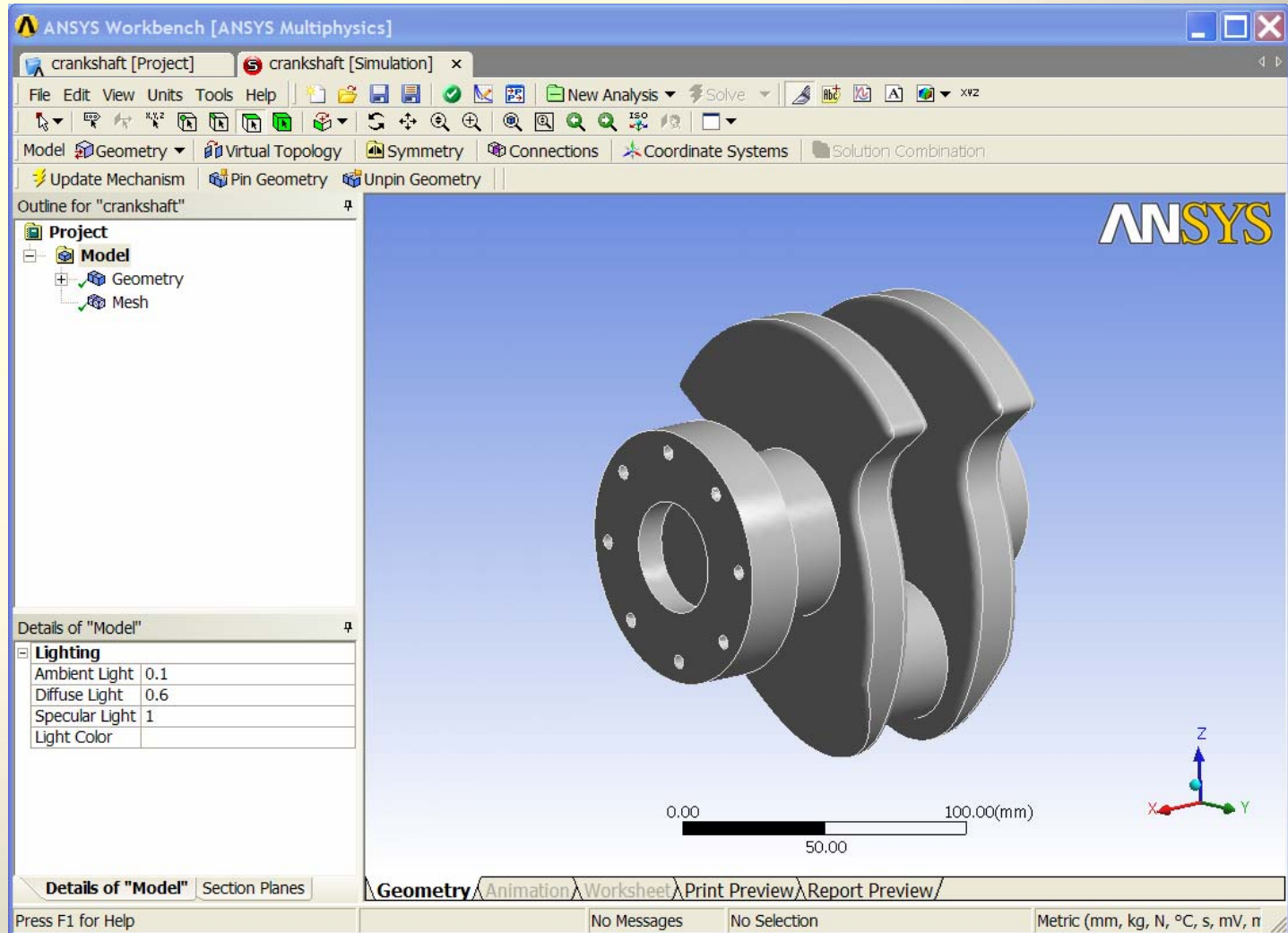
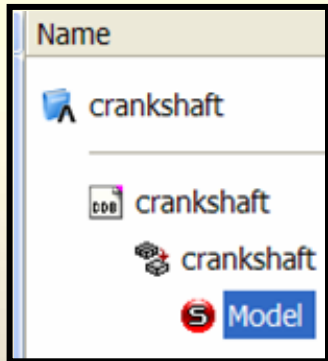
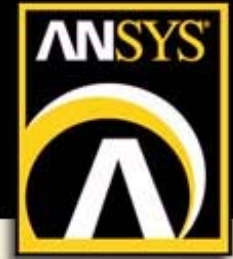

Working with Legacy Models

Design Simulation Results

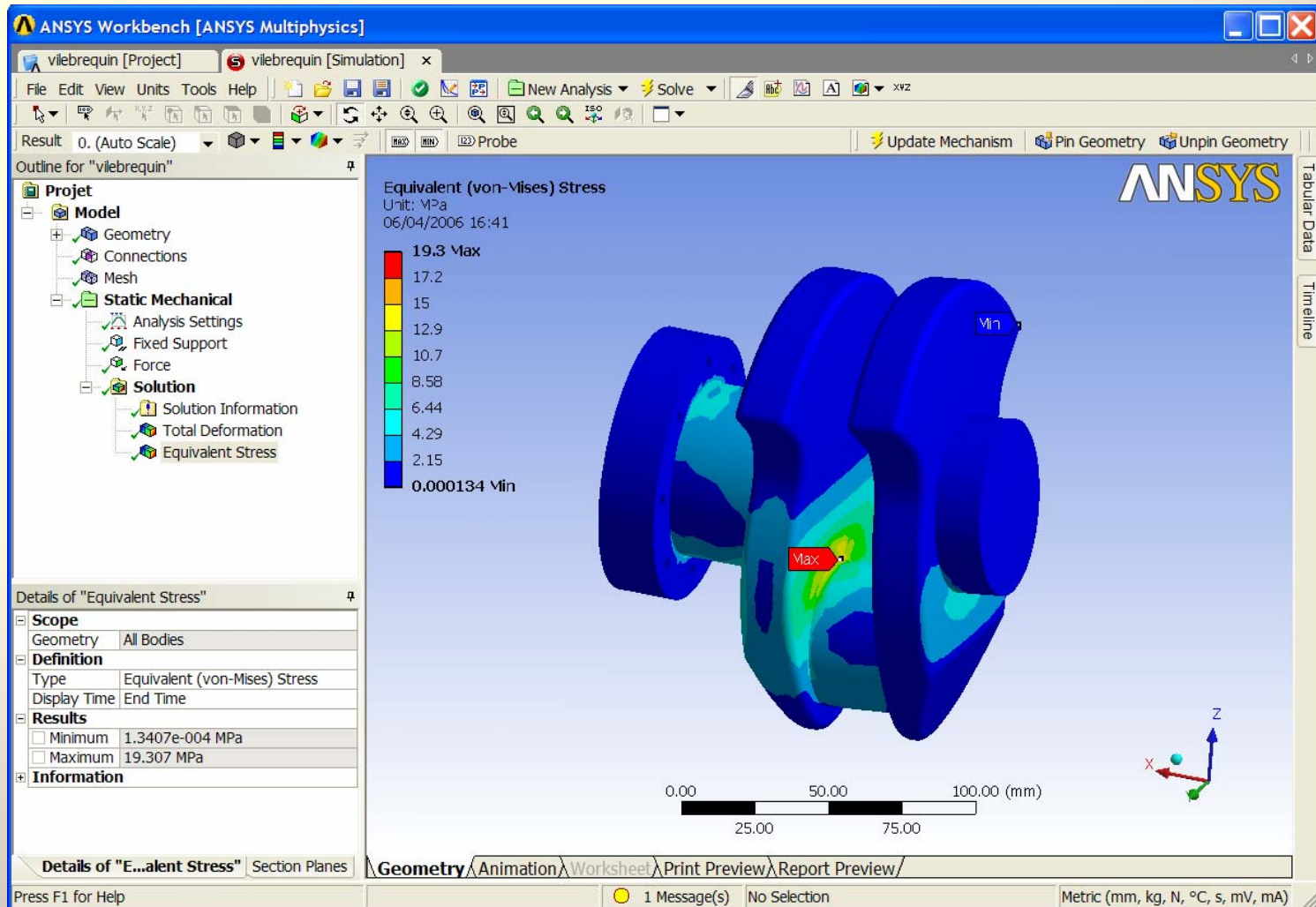
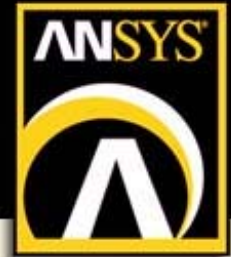

Optimization with Fatigue

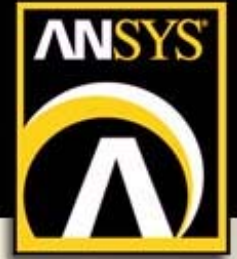

- Question:

What if you have a legacy model and wish to optimize the Fatigue Life?

- Answer:

FE Modeler, ANSYS Mesh Morpher and ANSYS DesignXplorer

Optimization with Fatigue

ANSYS Mesh Morpher Parametric Geometry

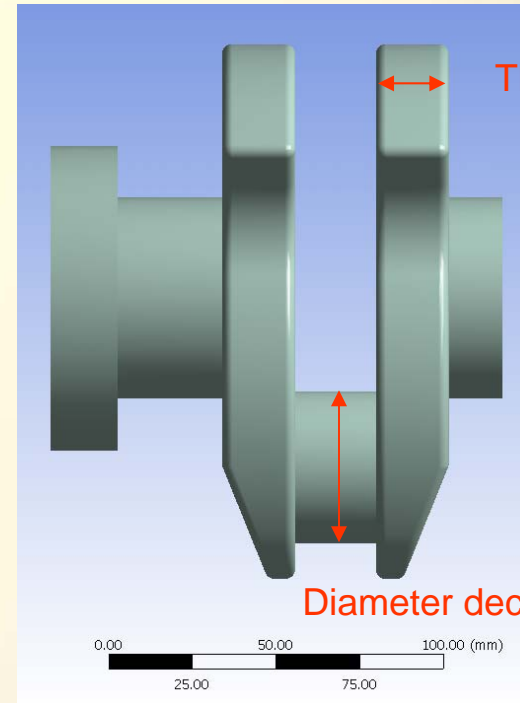
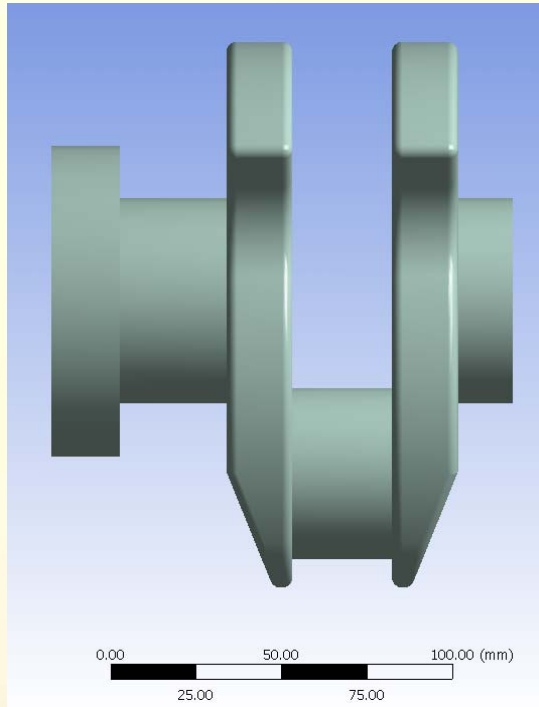
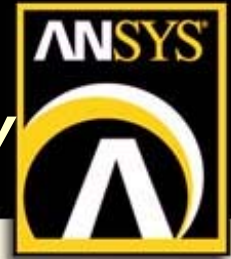

Thickness increase

Diameter decrease

Parameter Manager

| | Source | ID | Name | Current value | Expression |
|-------------------------------------|----------|----|----------------------|---------------|------------|
| <input checked="" type="checkbox"/> | ParaMesh | P2 | ParaMesh.Parameter.1 | 0 | |
| <input checked="" type="checkbox"/> | ParaMesh | P3 | ParaMesh.Parameter.2 | 0 | |

Ready

Parameter Manager

| | Source | ID | Name | Current value | Expression |
|-------------------------------------|----------|----|----------------------|---------------|------------|
| <input checked="" type="checkbox"/> | ParaMesh | P2 | ParaMesh.Parameter.1 | 2.5 | |
| <input checked="" type="checkbox"/> | ParaMesh | P3 | ParaMesh.Parameter.2 | -2 | |

Ready

Optimization with Fatigue

Design Simulation Results Stress Variations

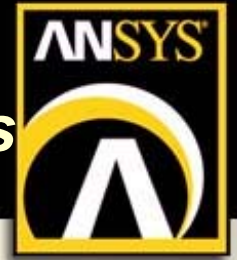

ANSYS

ANSYS

Equivalent (von-Mises) Stress
Unit: MPa
06/04/2006 16:46

Equivalent (von-Mises) Stress
Unit: MPa
06/04/2006 16:45

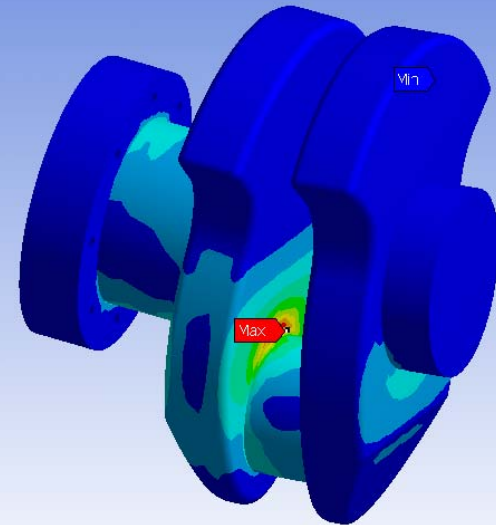
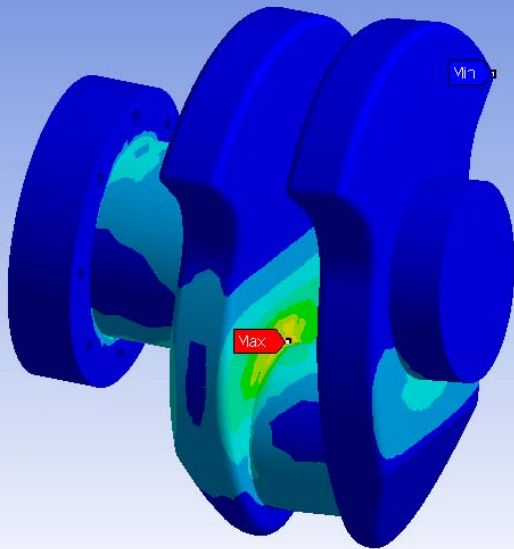
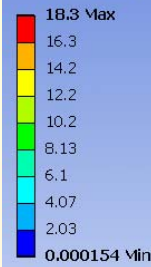
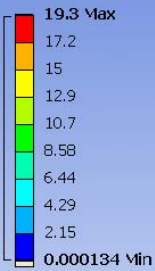

Optimization with Fatigue

Parameterize Fatigue Life then DX!

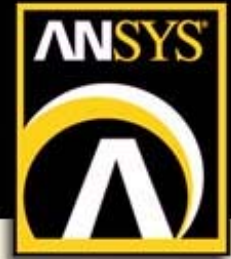

Equivalent (von-Mises) Stress
Unit: MPa
06/04/2006 16:45

ANSYS

18.3 Max
16.3
14.2
12.2
10.2
8.13
6.1
4.07
2.03
0.000154 Min

Min

Max

0.00 22.50 45.00 67.50 90.00

Details of "Life"

| | |
|-------------|------------|
| Scope | |
| Geometry | All Bodies |
| Definition | |
| Type | Life |
| Results | |
| Minimum | 20575 |
| Information | |

ANSYS Workbench [ANSYS Multiphysics/LS-DYNA]

suspension [Project] DX suspension [DesignXplorer]

File Edit View Insert Tools Help

Views

- Parameters
- Automatic Design Points
- Report

Parameters

Input Parameters

- Force Y Component
-5.5e-002 ← -5.e-002 → -4.5e-002
Initial Value = -5.e-002
- Force Z Component
-2.75e-002 ← -2.5e-002 → -2.25e-002
Initial Value = -2.5e-002
- Force X Component
0. ↔ 1.
Initial Value = 0.

Response Parameters

- Part 67 Mass
- Life Minimum**

Fatigue Within Workbench Fits Into Everyone's Process

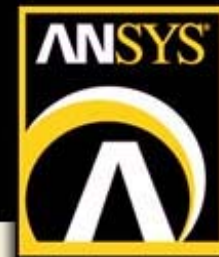

- Insert a Fatigue Tool
- Make Fatigue Decisions

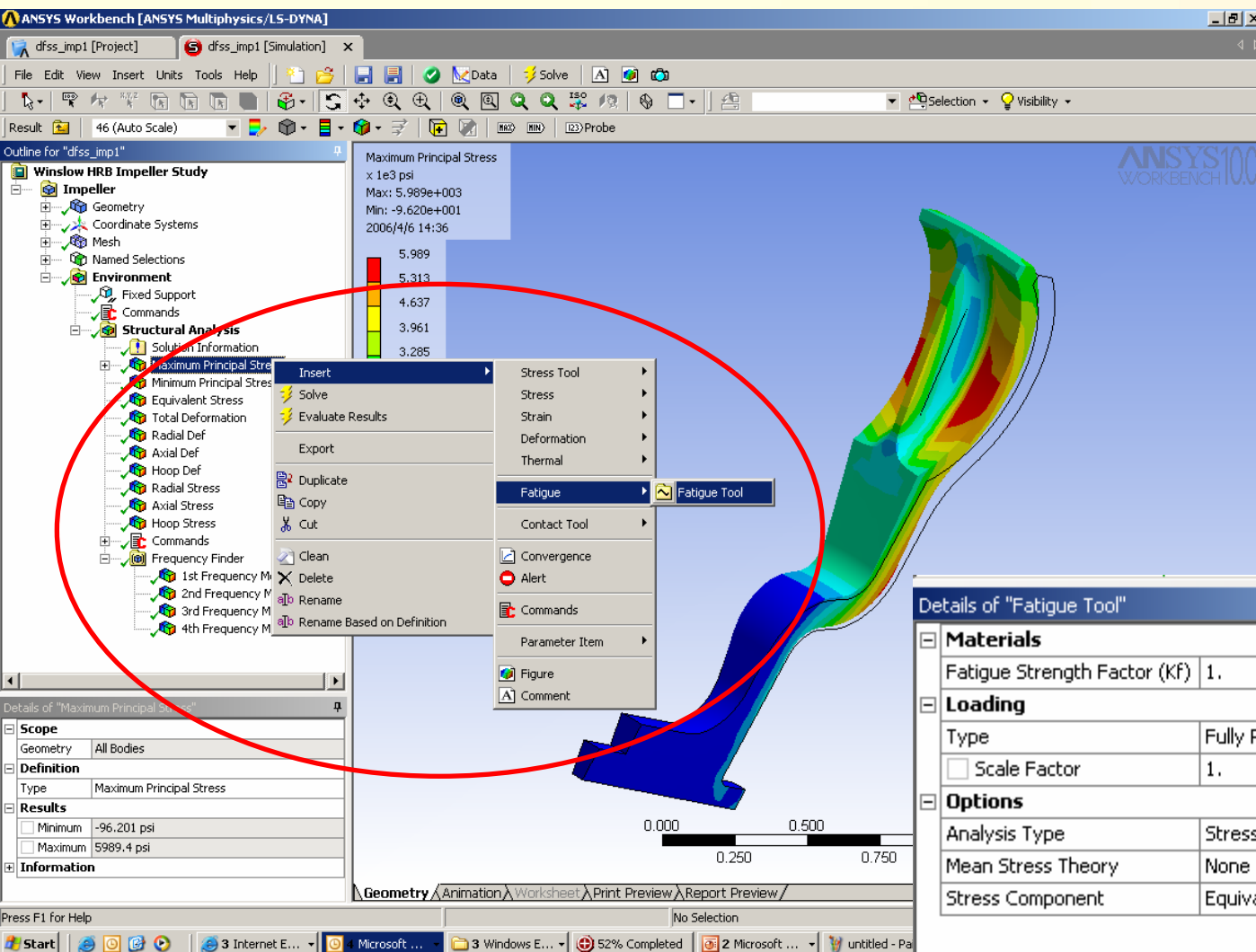

Details of "Fatigue Tool"

| | |
|---------------------------------------|------------------------|
| Materials | |
| Fatigue Strength Factor (Kf) | 1. |
| Loading | |
| Type | Fully Reversed |
| <input type="checkbox"/> Scale Factor | 1. |
| Options | |
| Analysis Type | Stress Life |
| Mean Stress Theory | None |
| Stress Component | Equivalent (Von Mises) |

Fatigue Within Workbench Fits Into Everyone's Process

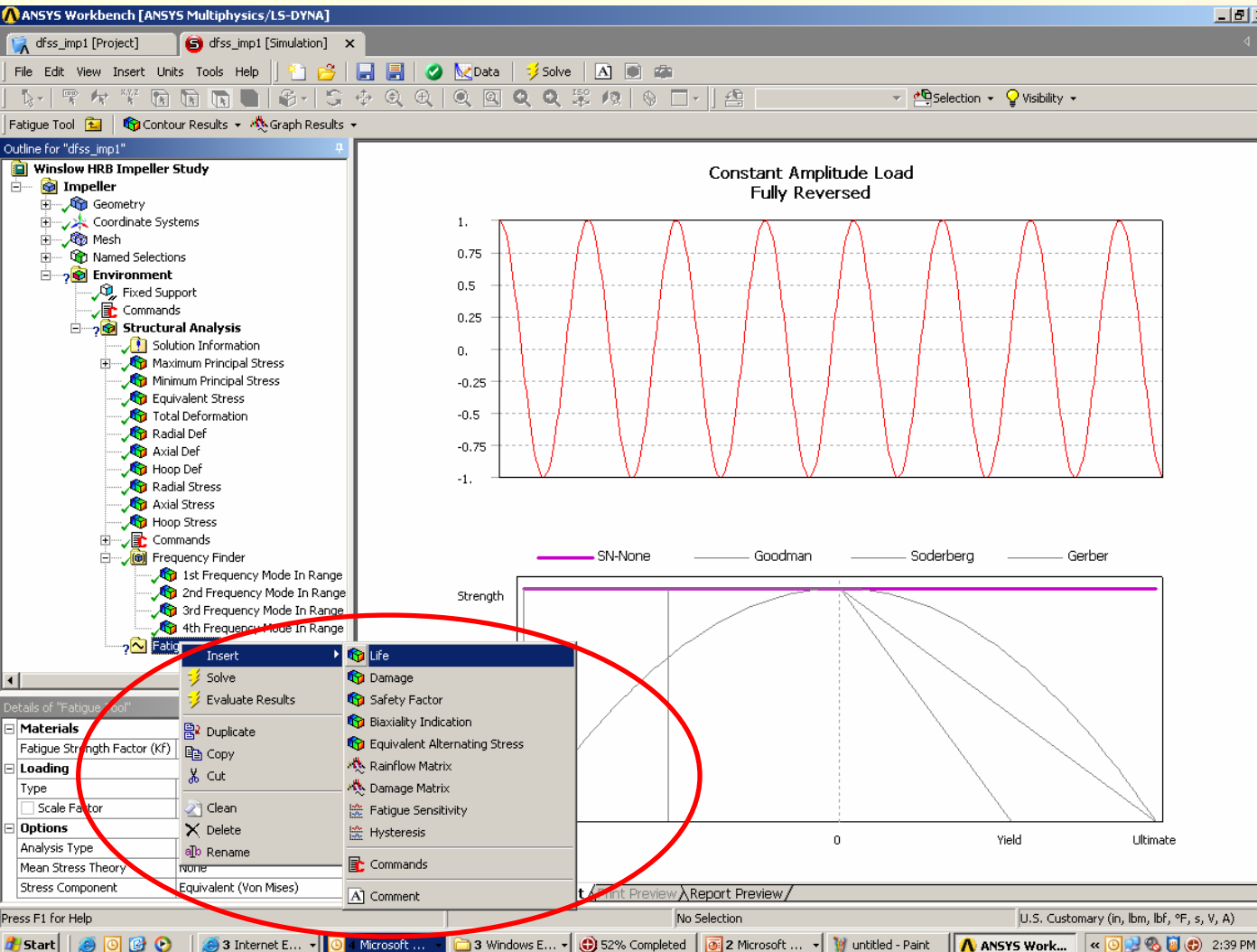
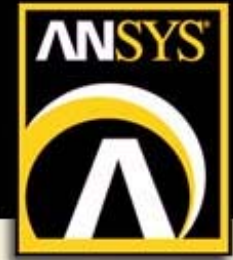

- Inset in Fatigue Results
 - Life
 - Factor of Safety
- Solve

Fatigue Within Workbench Fits Into Everyone's Process

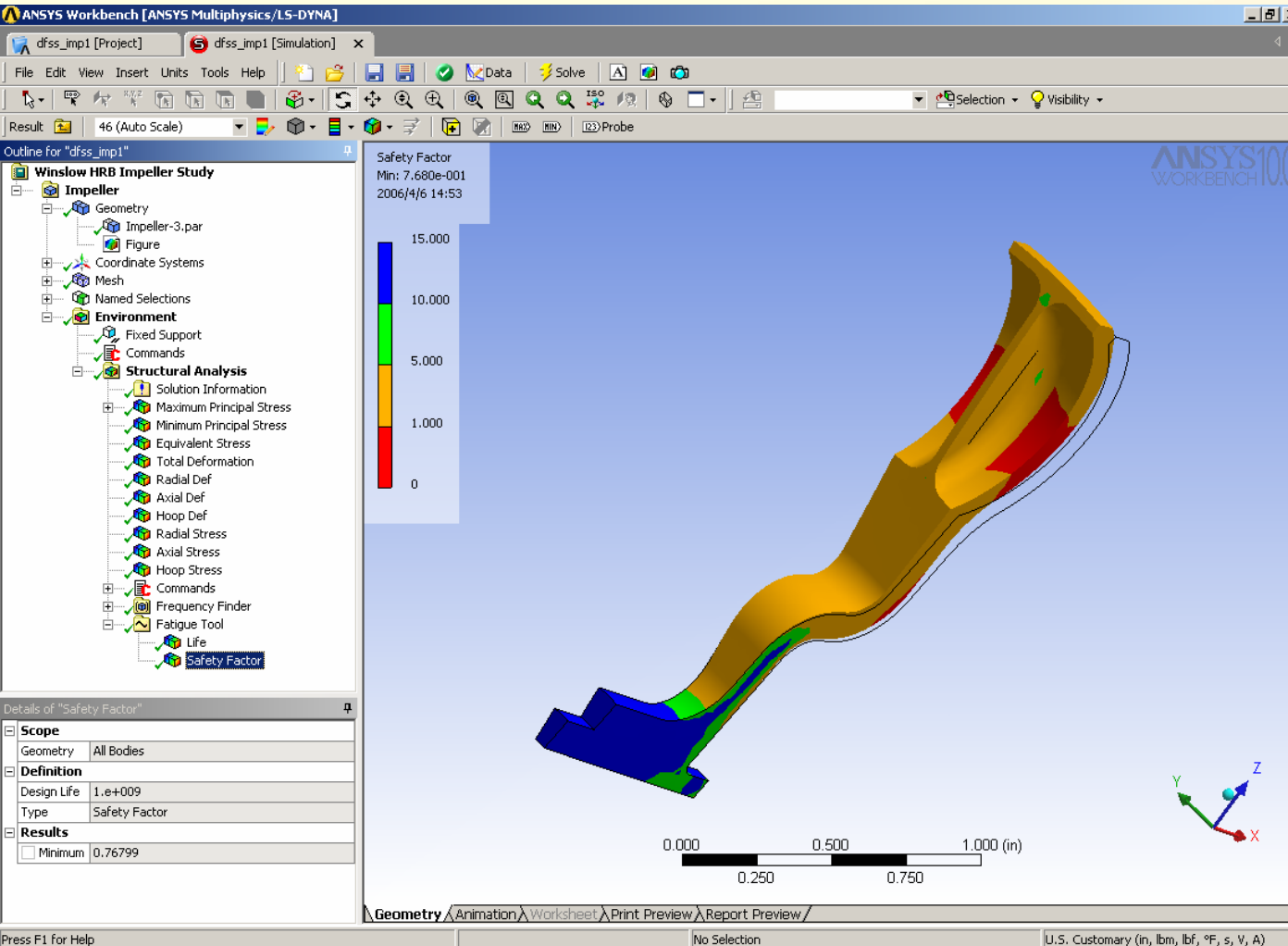
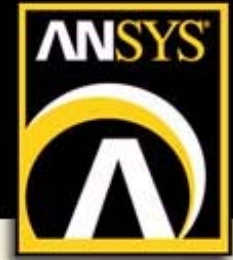

- Review Fatigue Results
 - Life
 - Factor of Safety

Fatigue Within Workbench Fits Into Everyone's Process

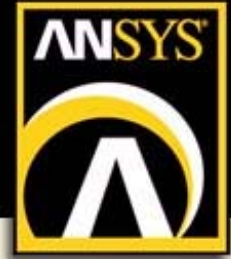

- **Insert a Fatigue Tool – 2 Clicks**
- **Make Fatigue Decisions - Varies**
- **Inset in Fatigue Results -**
 - **Life – 2 Clicks**
 - **Factor of Safety – 2 Clicks**
- **Solve – 1 Click**
- **Review Fatigue Results**
 - **Life – 1 Click**
 - **Factor of Safety – 1 Click**
- **Adding a Fatigue Analysis requires as little as six Mouse Clicks!!!!**

Fatigue Within Workbench Fits Into Everyone's Process!!!!

Predicting Fatigue Life with ANSYS Workbench

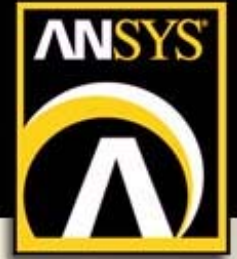

- Questions?

Ray Browell, P. E.

ANSYS, Inc.

(724) 514-3070

Ray.Browell@ANSYS.com