

Drehfeder in Baugruppe einfügen.

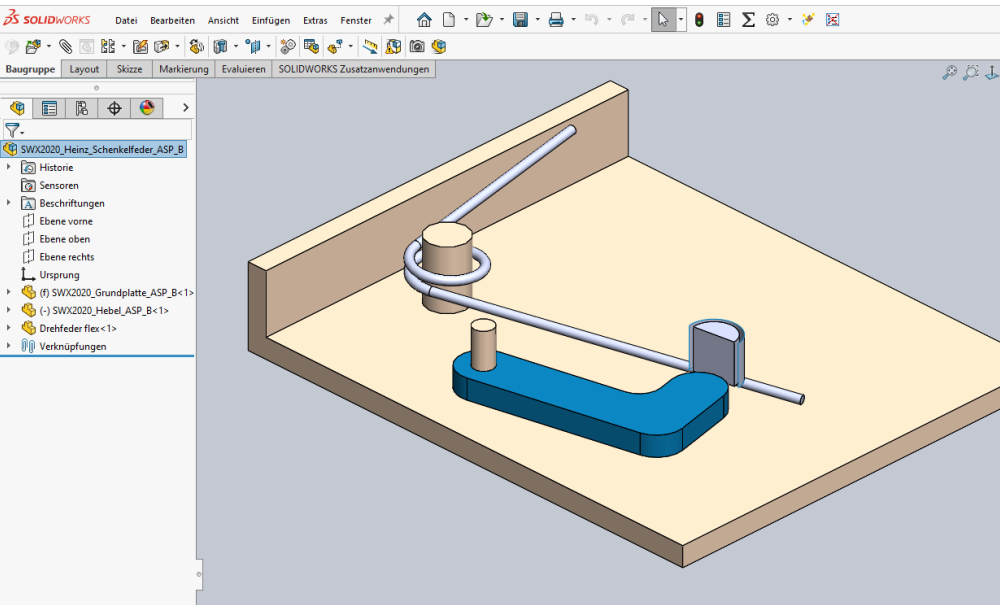

Oberfläche-Offset auf Hebel in BG beziehen.

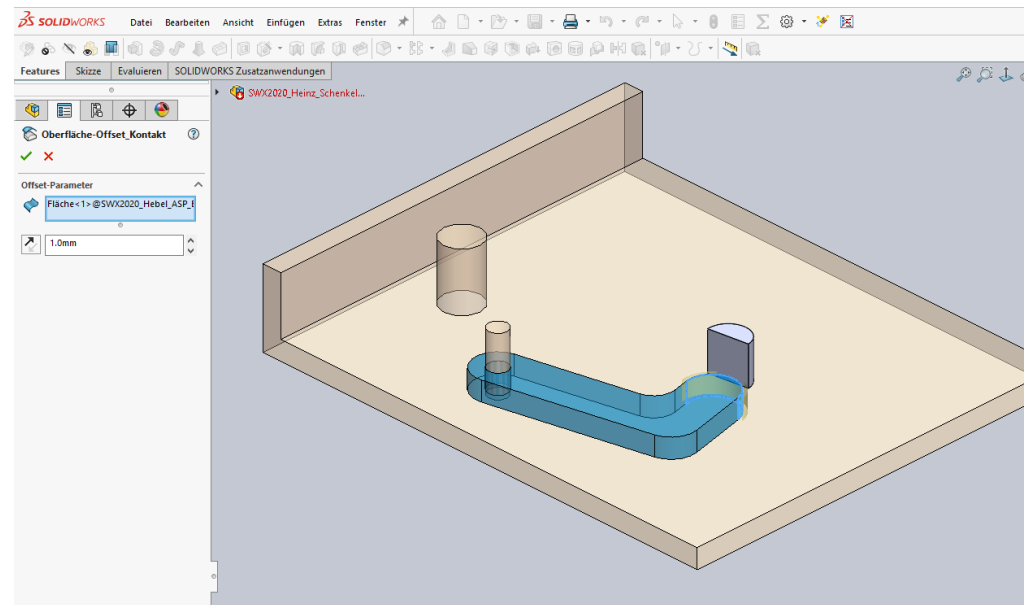

Flächenreferenz berichtigen.

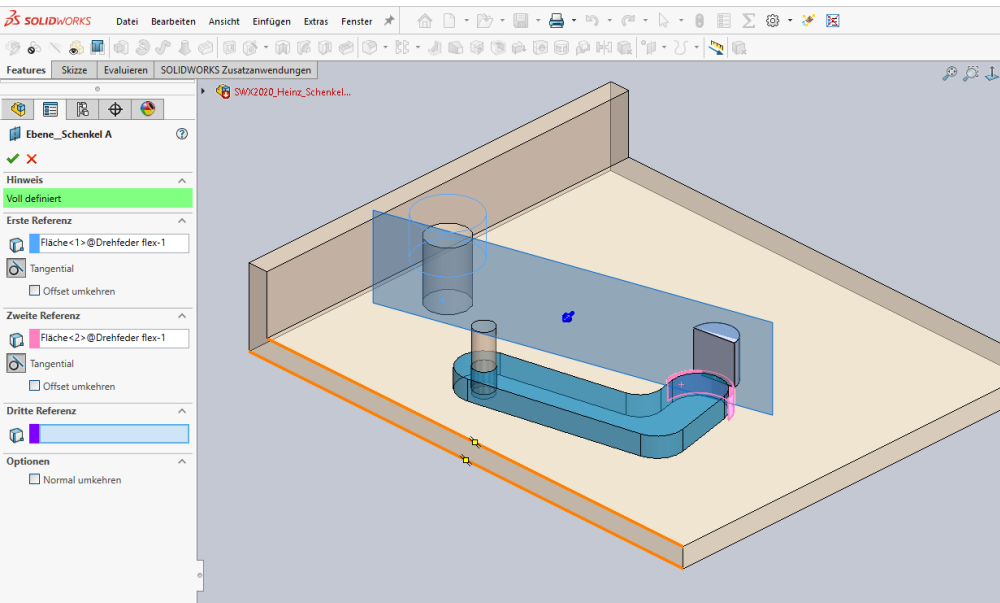

Temporären Aufsatz löschen.

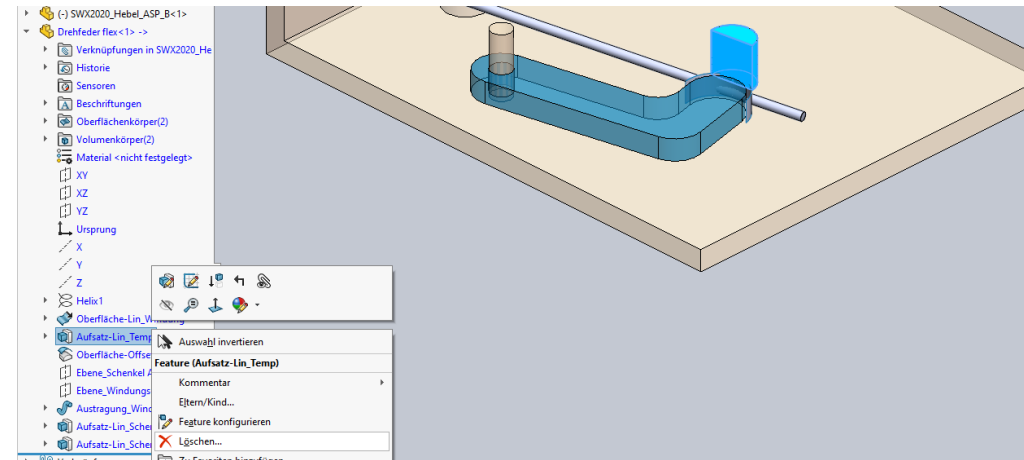

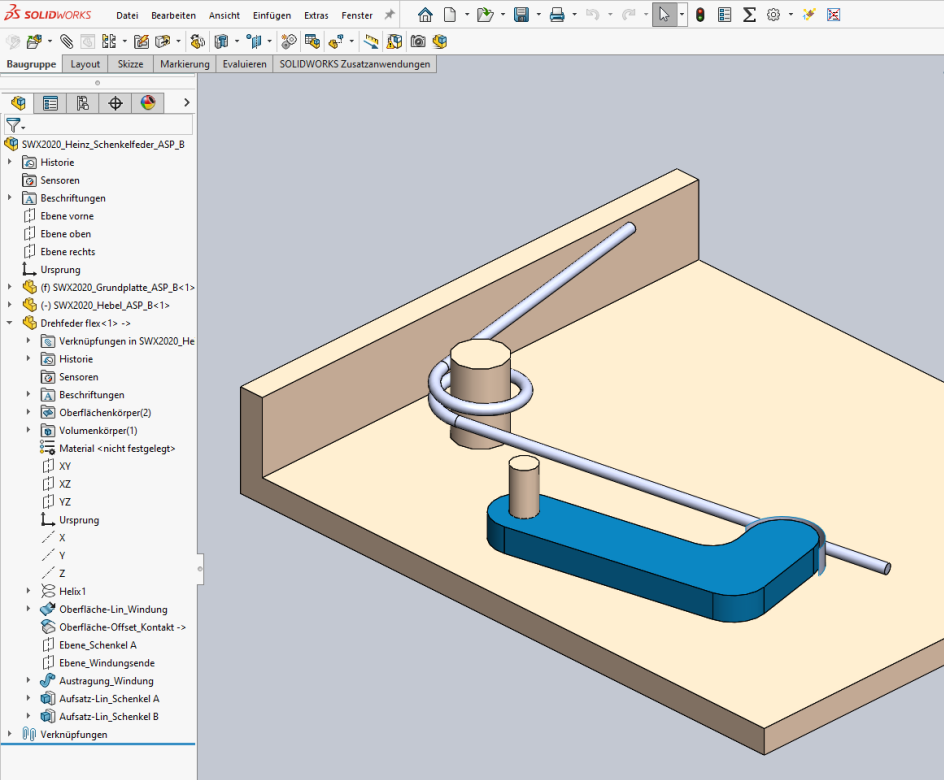

Beim einfügen der Drehfeder in eine weitere Baugruppe, die die Feder auf „Teil flexibel machen“ setzen und die externe Referenz neu zuordnen.

