

ITEM NUMBER	DESCRIPTION	COMMENTS
58 C13342 01 5011	425RD3H32-270 RH	
58 C13342 02 5011	425RD3H32-270 LH	
58 C13342 03 5011	425RD3H32-270 RH W/RELIEF	SEE NOTE #8
58 C13342 04 5011	425RD3H32-270 LH W/RELIEF	SEE NOTE #8

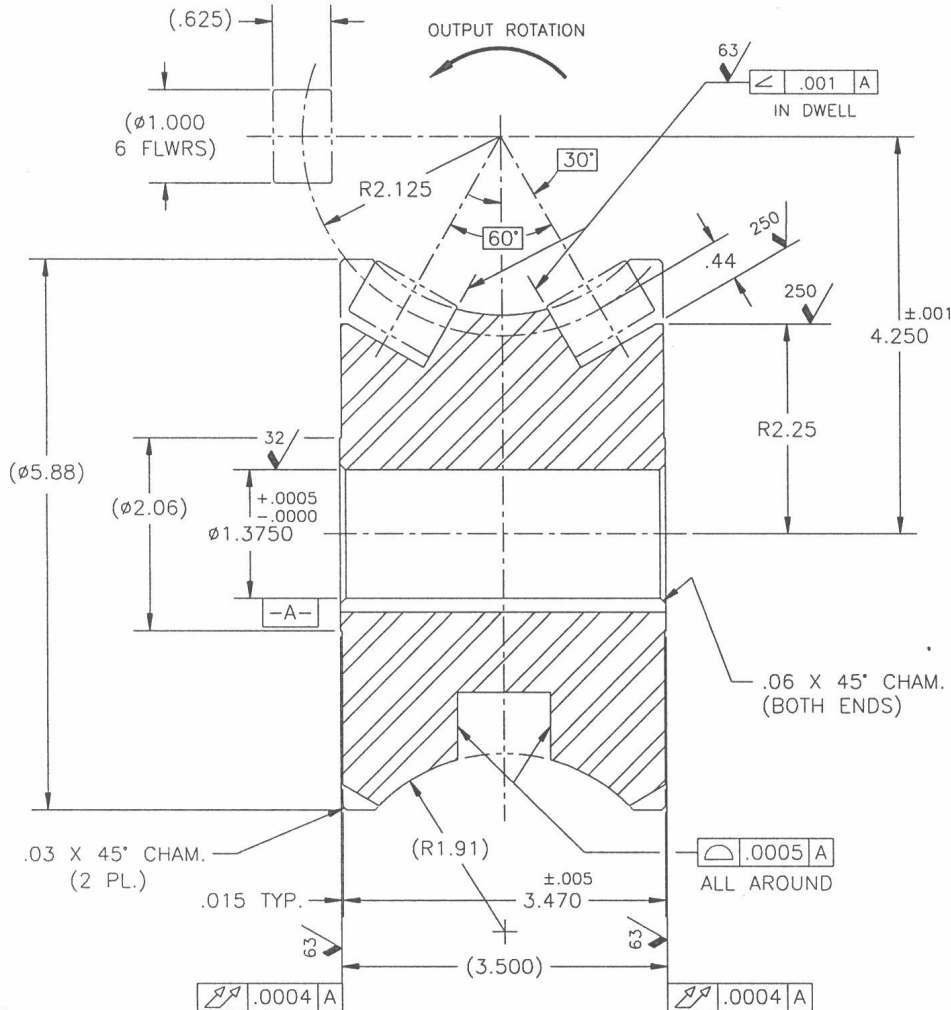

- NOTES:
- MOTION IS MODIFIED SINE W/ 0.00 CV.
 - HAND FINISH ENTRANCE AND EXIT TRACK TO R.19 MIN. ON LOWER PART OF TRACK (.37 MIN. THICKNESS).
 - HEAT TREAT PER CAMCO DWG. A-28508.
 - KEYWAY LOCATION IS AT MID-POINT OF MOTION
 - ARROWS SHOW RELATIVE ROTATION OF R.H. CAM. ORDER L.H. CAM TO REVERSE RELATIVE MOTION.
 - VIBRATION STRESS RELIEVE PER DWG. A-46772 DURING CYCLE.
 - FINISH CAM TRACK PER DWG. A-55822.
 - MACHINE DWELL RELIEF PER DESIGN STANDARD C-65445.

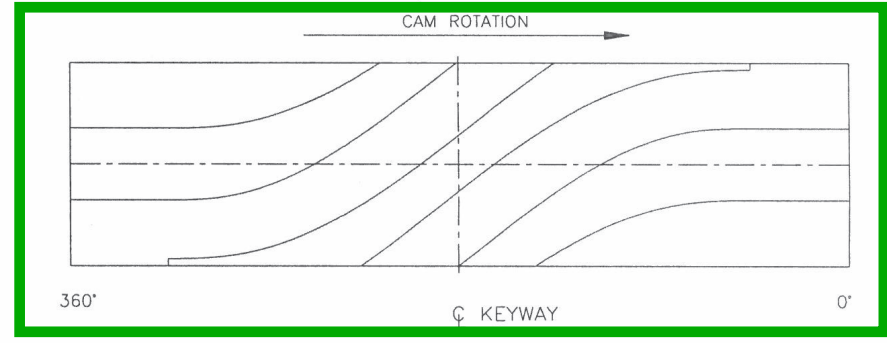

R.H. CAM TRACK DIAGRAM (REF ONLY)

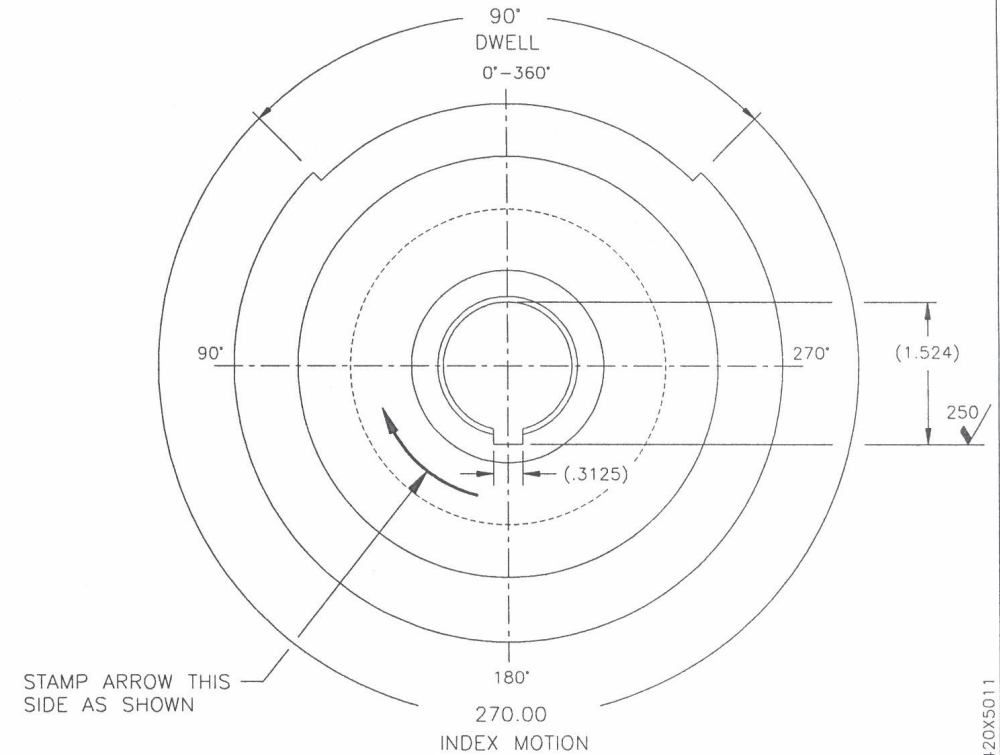

STAMP ARROW THIS SIDE AS SHOWN

CAM MACH,
425RD3H32-270

FMC KEN 05-16-73 1=1

58B11264015000 C-13342