

X (5:1)

Y (5:1)

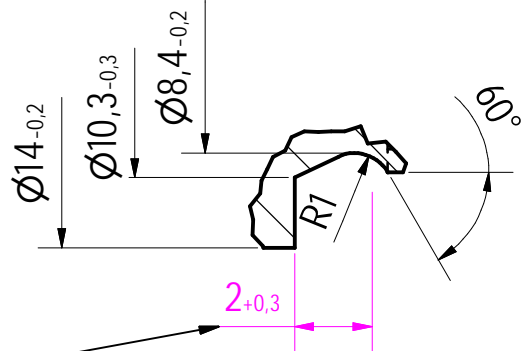

Diese Maße kann ich nicht mehr der Geometrie zuordnen

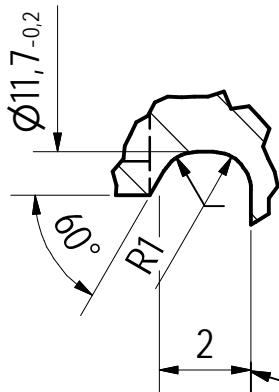
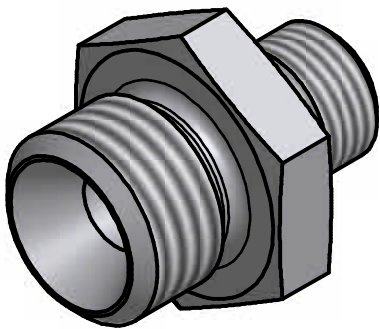

Oberflächenbehandlung:		Wärmebehandlung:		Allgemeintoleranzen ISO 2768-mK		Urheberrecht nach DIN 34		Maßstab: 2:1		Blatt 1 von 1	
								Werkstoff: SW19		X8CrNiS18-9 (1.4305)	
				Datum		Name		Doppelstutzen DN03-DN06 (M10x1-M14x1,5)			
				Gezeichnet 08.03.2005		M.Moser					
				Kontrolliert							
				Norm				HMB999000T074			
Status		Änderungen		Datum		Name		A4			
								M:\IV\HMB\HMB999000T074.idw			

